



Soutien lombaire réglable



Brevet Europe  
EP-B-2 121 377



Made in  
France



# RAID

SIÈGE ERGONOMIQUE POUR UN MAINTIEN OPTIMAL

- Ergonomischer Sitz für optimale Unterstützung
- Ergonomic seat for optimal support
- Asiento ergonómico para un apoyo óptimo



Option soutien cervical



Vide-poches arrière

Le plus : maintien idéal



Maintien latéral - assise anti-soumarinage



**SCOPEMA**  
RIB SEATING SINCE 1981

RAID

RIB

# RAID

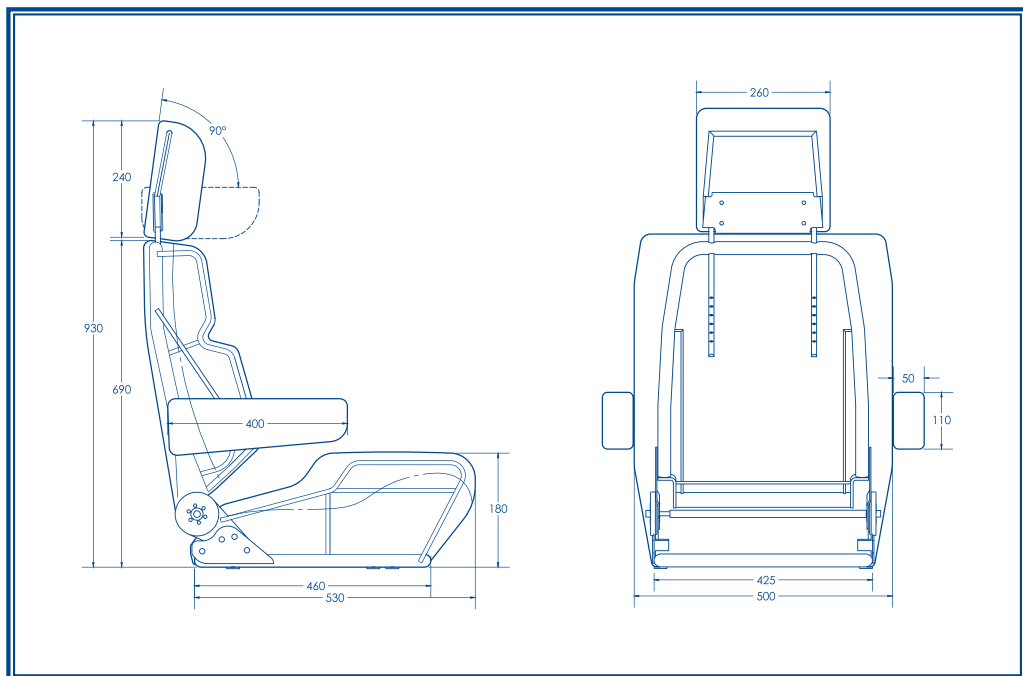

## CARACTÉRISTIQUES

### Standard

- Homologation européenne TÜV n° 93SG0316-00
- Soutien lombaire réglable en hauteur et en volume
- Mousse «Scopex» Haute Densité
- Renforts latéraux de maintien
- Articulation à double verrouillage
- Calage anti-soumarinage
- Appuie-tête inclinable et réglable en hauteur
- Vide poche arrière

### Option

- Adaptation homologuée pour les principaux véhicules
- Accoudoirs relevables
- Accoudoirs relevables et réglables en inclinaison
- Soutien cervical réglable en hauteur

## MERKMALE

### Standard

- TÜV Prüfung Nr. 93SG0316-00
- Höhenverstellbare und aufblasbare Rückenstütze
- «SCOPEX» Schaumstoff mit hoher Dichte
- Seitliche Unterstützung für eine bessere Haltung
- Gelenksystem mit Doppelverriegelung
- Vorrichtung gegen Rutschgefahr
- Neigbare und höhenverstellbare Kopfstütze
- Staufach hinter dem Sitz

### Wahlweise

- Geprüfter Adapter für die wichtigsten Fahrzeuge
- Aufklappbare Armstützen
- Aufklappbare und schrägstellbare Armstützen
- Höhenverstellbare Nackenstütze

## CHARACTERISTICS

### Standard

- TÜV European approval n° 93SG0316-00
- Height and volume adjustable lumbar support
- High density "Scopex" foam
- Lateral upholding reinforcement
- Double-bolt joint system
- Anti-body slide blocking system
- Tilttable and height adjustable headrest
- Console storage compartment

### Option

- Approved adapter for the most important vehicles
- Lift-up arm-rest
- Lift-up and reclining arm-rest
- Height adjustable cervical (neck) support

## CARACTERÍSTICAS

### Norma

- Homologación Europea TÜV N° 96SG0316-00
- Sostén lumbar ajustable en altura y en volumen
- Espuma "SCOPEX" alta densidad
- Refuerzos rigidez laterales
- Articulaciones dobles autoblocantes
- Rebaje anti deslizamiento
- Reposacabezas reclinable y ajustable en altura
- Bolsillo trasero

### Opción

- Adaptación aprobada para los principales vehículos
- Reposabrazos móviles
- Reposabrazos móviles y ajustables en inclinación
- Apoyo cervical ajustable en altura



Brevet Europe  
EP-B-2 121 377



Made in  
France

# KILIMANDJARO

CONÇU POUR LES LONGS TRAJETS

- Entwickelt für lange Reisen
- Designed for long journeys
- Diseñado para viajes largos



Version Classic



Version Confort



2 versions : Classic et Confort



Vide poche



Assise anti-soumarinage  
et maintien latéral



RIB

# KILIMANDJARO

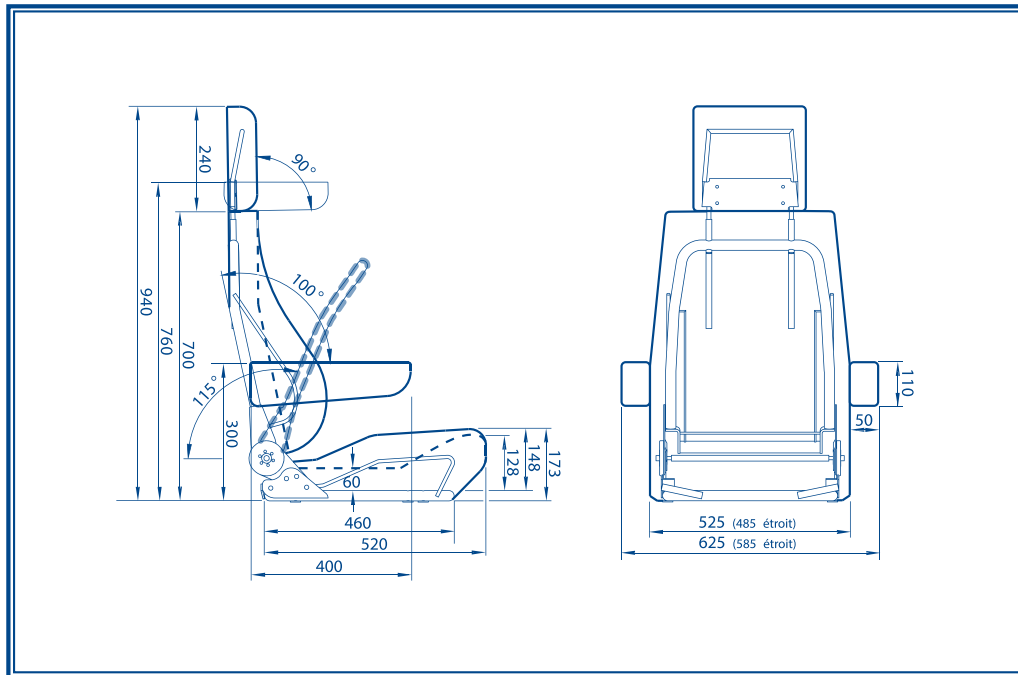

## 🇫🇷 CARACTÉRISTIQUES

### Standard

- Homologation européenne TÜV n° 93SG0316-00
- Soutien lombaire réglable en hauteur et en volume
- Mousse «Scopex» Haute Densité
- Renforts latéraux de maintien
- Articulation double verrouillage
- Calage anti-soumarinage
- Appuie-tête inclinable (sauf Classic) et réglable en hauteur
- Vide poche arrière

### Option

- Adaptation homologuée pour les principaux véhicules
- Accoudoirs relevables
- Accoudoirs relevables et réglables en inclinaison
- Soutien cervical réglable en hauteur

## 🇩🇪 MERKMALE

### Standard

- TÜV Prüfung Nr. 93SG0316-00
- Höhenverstellbare und aufblasbare Rückenstütze
- «SCOPEX» Schaumstoff mit hoher Dichte
- Seitliche Unterstützung für eine bessere Haltung
- Gelenksystem mit Doppelverriegelung
- Vorrichtung gegen Rutschgefahr
- Neigbare und höhenverstellbare Kopfstütze (außer "Classic")
- Staufach hinter dem Sitz

### Wahlweise

- Geprüfter Adapter für die wichtigsten Fahrzeuge
- Aufklappbare Armstützen
- Aufklappbare und schrägstellbare Armstützen
- Höhenverstellbare Nackenstütze

## 🇬🇧 CHARACTERISTICS

### Standard

- TÜV European approval n° 93SG0316-00
- Height and volume adjustable lumbar support
- High density "Scopex" foam
- Lateral upholding reinforcement
- Double-bolt joint system
- Anti-body slide blocking system
- Tilttable (except "Classic") and height adjustable headrest
- Console storage compartment

### Option

- Approved adapter for the most important vehicles
- Lift-up arm-rest
- Lift-up and reclining arm-rest
- Height adjustable cervical (neck) support

## 🇪🇸 CARACTERÍSTICAS

### Norma

- Homologación Europea TÜV N° 96SG0316-00
- Sostén lumbar ajustable en altura y en volumen
- Espuma "SCOPEX" alta densidad
- Refuerzos laterales de mantenimiento
- Articulaciones dobles autoblocantes
- Calzo anti deslizamiento
- Reposacabezas inclinable (excepto "Classic") y ajustable en altura
- Bolsillo trasero

### Opción

- Adaptación aprobada para los principales vehículos
- Apoya Brazos móviles
- Apoya Brazos móviles y ajustables en inclinación
- Apoyo cervical ajustable en altura



Brevet Europe  
EP-B-2 121 377



Made in  
France



Dossier à inclinaison réglable

# BOOSTER

LE PLUS ÉCONOMIQUE

- Die wirtschaftlichste
- The most economical
- El mas economico



Siège à faible encombrement



Option : molettes pour le réglage des accoudoirs



**SCOPEMA**  
RIB SEATING SINCE 1981



# BOOSTER

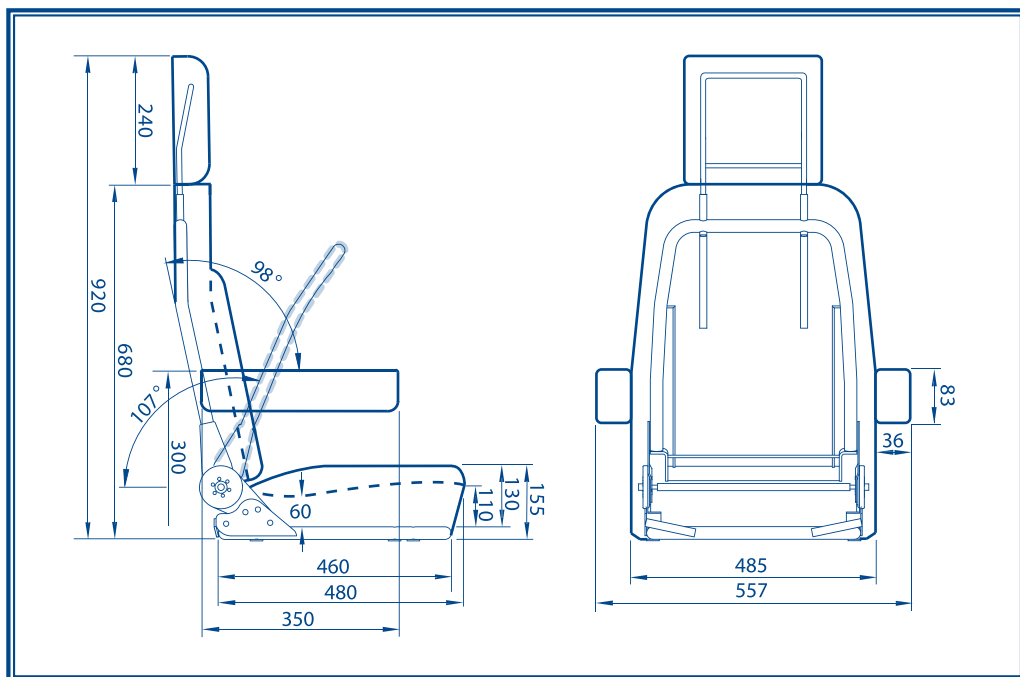

## 🇫🇷 CARACTÉRISTIQUES

### Standard

- Homologation européenne TÜV n° 93SG0316-00
- Mousse polyester
- Articulation à simple verrouillage

### Option

- Adaptation homologuée pour les principaux véhicules
- Accoudoirs relevables
- Accoudoirs relevables et réglables en inclinaison

## 🇩🇪 MERKMALE

### Standard

- TÜV Prüfung Nr. 96SG0316-00
- Polyester Schaumstoff
- Gelenksystem mit Einzelverriegelung

### Wahlweise

- Geprüfter Adapter für die wichtigsten Fahrzeuge
- Aufklappbare Armstützen
- Aufklappbare und schrägstellbare Armstützen

## 🇬🇧 CHARACTERISTICS

### Standard

- TÜV European approval Nr 96SG0316-00
- Polyester foam
- Single-bolt joint system

### Option

- Approved adapter for the most important vehicles
- Lift-up arm-rest
- Lift-up and reclining arm-rest

## 🇪🇸 CARACTERÍSTICAS

### Norma

- Homologación Europea TÜV n° 96SG0316-00
- Espuma Poliéster
- Articulaciones autoblocantes

### Opción

- Adaptación aprobada para los principales vehículos
- Apoya Brazos móviles
- Apoya Brazos móviles y ajustables en inclinación



Épaisseur : 21 mm



Made in  
France

# EMBASES TOURNANTES HOMOLOGUÉES V3

- ATEEL geprüfte Drehkonsolen
- ✚ Approved seat swivels
- Plataformas giratorias homologadas



Homologuées pour de nombreux modèles

Homologation Européenne n° FRSCP1-VR-00001

Modèle Ford Transit Custom V710 / VW T7



Modèle : Renault Trafic X82 / Opel Vivaro /  
Nissan NV 300 / Fiat Talento



Modèle VW ID BUZZ/VW T7 Multivan



Modèle Mercedes Sprinter



# EMBASES TOURNANTES HOMOLOGUÉES

- Homologation européenne ATEEL n° FRSCP1-VR-00001
- ATEEL Prüfung Nr FRSCP1-VR-00001
- European approval Nr FRSCP1-VR-00001
- Homologación europea Nr FRSCP1-VR-00001

- Points de fixation d'origine (pour chaque modèle)
- Original Befestigungspunkte (für jedes Modell)
- Original fixation points (for each model)
- Puntos de fijación de origen (para cada modelo)

- Stabilisateurs
- Stabilisatoren
- Stabilizers
- Estabilizadores

- Plaques acier ép. 4mm
- Stahlplatte 4 mm Dicke
- Steelplates 4 mm thick
- Placa de acero de 4 mm

- Déverrouillage facile
- Leichte Entriegelung
- Easy unlock
- Desbloqueo fácil

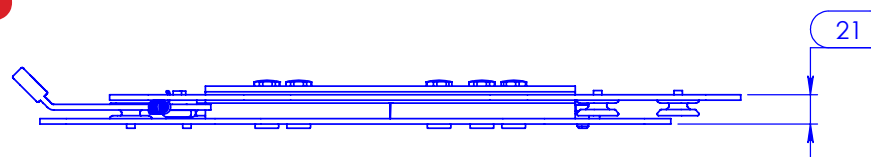

21

- Épaisseur : 21 mm
- Dicke : 21 mm
- Thickness : 21 mm
- Grosor : 21 mm

- Déport vers l'arrière : de 0 à 160 mm (suivant les modèles)
- Drehpunkt zwischen 0 und 160 mm nach hinten versetzt (je nach dem Modell)
- Offset facing rear: from 0 to 160 mm (depending on the model)
- Desplazamiento hacia atrás: de 0 hasta 160 mm (según los modelos)

- Verrouillage automatique face à la route
- Automatische Verriegelung in Fahrtrichtung
- Automatic locking facing forward
- Bloqueo automático orientación hacia delante

- Déport vers l'intérieur : de 0 à 60 mm (suivant les modèles)
- Drehpunkt zwischen 0 und 60 mm zur Mitte versetzt (je nach dem Modell)
- Offset facing inwards: from 0 to 60 mm (depending on the model)
- Desplazamiento medio hacia el interior: de 0 hasta 60 mm (según los modelos)

- Poids : 8.5 kg
- Gewicht : 8.5 Kg
- Weight : 8.5 kg
- Peso : 8.5 kg





Épaisseur : 23 mm



Brevet Europe  
EP-B-2 121 377



Made in  
France



# EMBASES TOURNANTES HOMOLOGUÉES V2

- 🇩🇪 TÜV geprüfte Drehkonsolen
- 🇬🇧 Approved seat swivels
- 🇪🇺 Plataformas giratorias homologadas

Homologuées pour de nombreux modèles

Homologation Européenne n° 93SG013-00



Modèle Ford Transit Custom



Modèle : Renault Traffic X82 / Opel Vivaro /  
Nissan NV 300 / Fiat Talento



Modèle VWT5/VWT6 Pilote



Modèle Mercedes Sprinter/VW Crafter



# EMBASES TOURNANTES HOMOLOGUÉES

- Homologation européenne TÜV n° 93SG0316-00
- TÜV Prüfung Nr 93SG0316-00
- European approval Nr 93SG0316-00
- Homologación europea Nr 93SG0316-00

- Points de fixation d'origine (pour chaque modèle)
- Original Befestigungspunkte (für jedes Modell)
- Original fixation points (for each model)
- Puntos de fijación de origen (para cada modelo)

- Stabilisateurs
- Stabilisatoren
- Stabilizers
- Estabilizadores

- Plaques acier ép. 5mm
- Stahlplatte 5 mm Dicke
- Steelplates 5 mm thick
- Placa de acero de 5 mm

- Déverrouillage facile
- Leichte Entriegelung
- Easy unlock
- Desbloqueo fácil



- Épaisseur : 23 mm
- Dicke : 23 mm
- Thickness : 23 mm
- Grosor : 23 mm

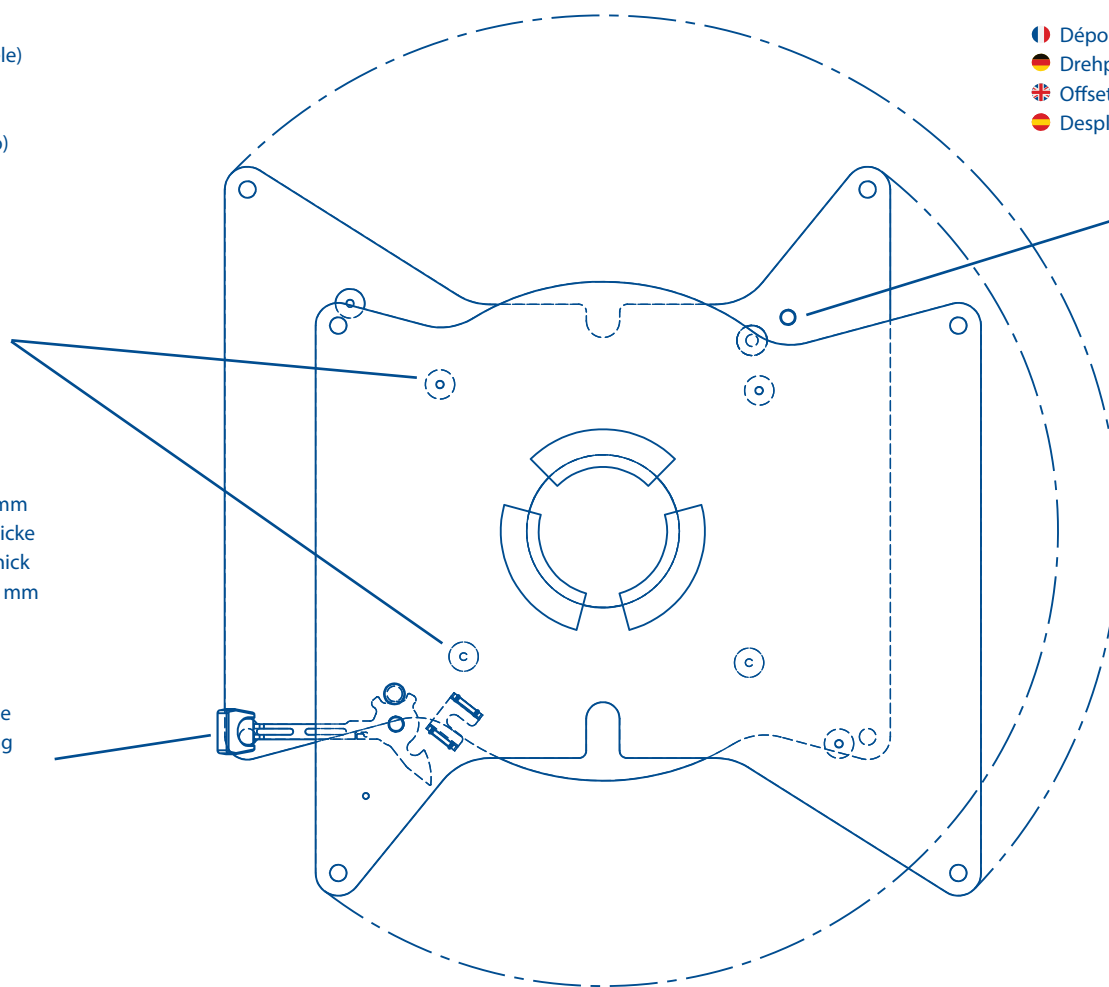

- Déport vers l'arrière : de 0 à 160 mm (suivant les modèles)
- Drehpunkt zwischen 0 und 160 mm nach hinten versetzt (je nach dem Modell)
- Offset facing rear: from 0 to 160 mm (depending on the model)
- Desplazamiento hacia atrás: de 0 hasta 160 mm (según los modelos)

- Verrouillage automatique face à la route
- Automatische Verriegelung in Fahrtrichtung
- Automatic locking facing forward
- Bloqueo automático orientación hacia delante

- Déport moyen vers l'intérieur : de 0 à 60 mm
- Drehpunkt zwischen 0 und 60 mm zur Mitte versetzt (je nach dem Modell)
- Offset facing inwards: from 0 to 60 mm
- Desplazamiento medio hacia el interior: de 0 hasta 60 mm

- Poids : 12 kg
- Gewicht : 12 Kg
- Weight : 12 kg
- Peso : 12 kg



Brevet Europe  
EP-B-2 121 377



Made in  
France



# ALTAÏR 3P

- DOUBLE DOSSIER, COUCHAGE COMPLET • CEINTURES 3 POINTS INTÉGRÉES
- Zweite Rückenlehne, komplette Schlaf- und Sitzbank. Integrierte Dreipunktgurte
- Double Back-Rest, Complete Sleeping • Integral 3 Points Belts
- Doble Respaldo, completo dormir • Cinturones 3 puntos integrados



Banquette 3 places



Banquette 2 places



Positions de couchage



# ALTAÏR 3P

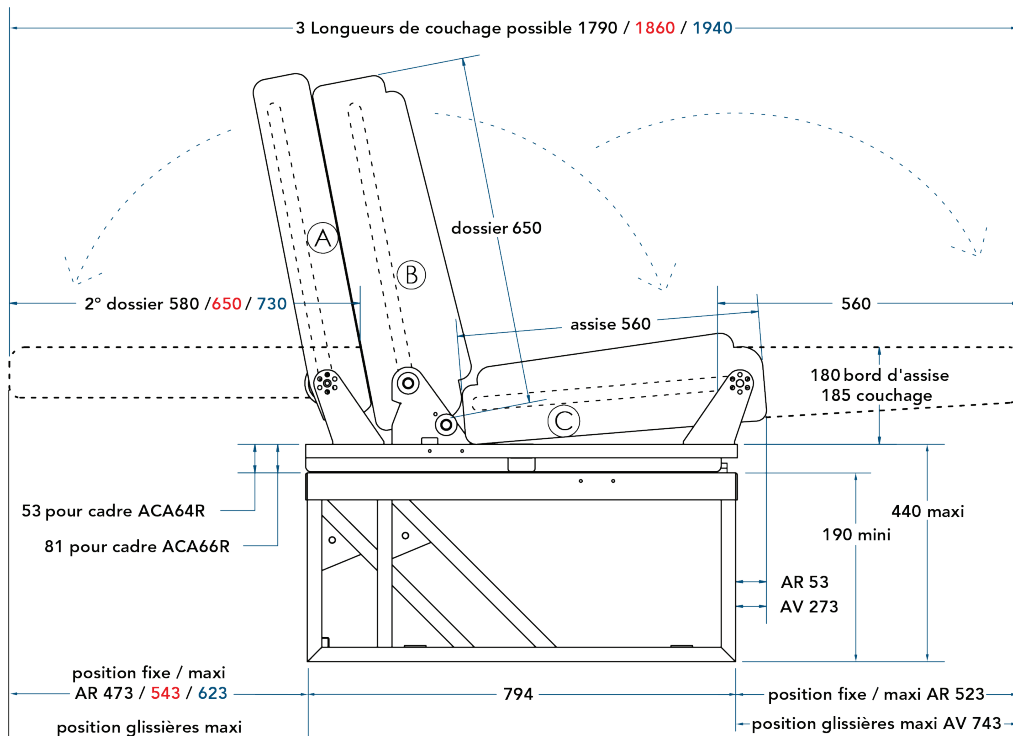

## LÉGENDE

- A. Dossier arrière
- B. Dossier avec ceintures intégrées
- C. Assise

## LEGEND

- A. Rear Backrest
- B. Backrest with integral belts
- C. Sitting

## LEGENDE

- A. Hintere Lehne Herunterklappbar zur Bettverlängerung
- B. Rückenlehne mit integrierten Gurten
- C. Sitzfläche

## LEYENDA

- A. Expediente posterior
- B. Expediente con cinturones integrados
- C. Base

## CARACTÉRISTIQUES

### Standard

- Homologation européenne
- Mousse «Scopex» Haute Densité
- Largeur des banquettes :
  - 600 mm
  - 860-940-1040-1120-1200 mm
  - 1200-1290-1400-1500 mm
- Houssage matelassé
- Blocage automatique du dossier en position route
- Système Isofix Top Tether

### Option

- Appuis-tête intégrés
- Accoudoirs relevables intégrés (latéral/central)
- 2ème dossier 580 ou 730 mm (au lieu de 650)
- Surmatelas 3D intégré côté couchage
- Glissières
  - Longitudinales 220 mm
  - Latérales 220 mm

## CHARACTERISTICS

### Standard

- European Approval
- High Density «Scopex» foam
- Width of the benchseats :
  - 600 mm
  - 860-940-1040-1120-1200 mm
  - 1200-1290-1400-1500 mm
- Quilted seat-covering
- Automatic stoppage of the backrest
- Isofix Top Tether System

### Option

- Integrated headrests
- Integrated lift-up arm-rest (lateral or central)
- 2nd backrest 580 or 730 mm (instead of 650 mm)
- Integrated 3D mattress overlay (sleeping side)
- Sliders
  - 220 mm lengthwise
  - 220 mm lateral

## EIGENSCHAFTEN

### Standard

- EEC Prüfung
- «Scopex» Schaumstoff mit hoher Raumdichte
- Breite der Bänke :
  - 600 mm
  - 860-940-1040-1120-1200 mm
  - 1200-1290-1400-1500 mm
- Abgesteppte Sitzbankbezüge
- Automatische Verriegelung der Rückenlehne
- Isofix Top Tether System

### Optional

- Integrierte Kopfstützen
- Integrierte Klappbare Armlehnen (seitlich oder zentral)
- Hintere Lehne. Herunterklappbar zur Bettverlängerung 580 oder 730 mm (statt 650 mm)
- Integrierte 3D Schlafpolsterauflage
- Führungsschienen zwischen Unterbock und Polsterung für
  - 220 mm Längsverschiebung
  - 220 mm Querverschiebung

## CARACTERÍSTICAS

### Norma

- Homologación Europea
- Espuma «Scopex» alta densidad
- Ancho de los asientos :
  - 600 mm
  - 860-940-1040-1120-1200 mm
  - 1200-1290-1400-1500 mm
- Fundas acolchadas
- Bloqueo automático del respaldo
- Sistema Isofix Top Tether

### Opción

- Reposacabezas integrados
- Reposabrazos móviles integrados (lateral/central)
- Segundo respaldo 580 o 730 mm (al lugar de 650 mm)
- 3D colchón costado dormir
- Guías correderas
  - Longitudinales 220 mm
  - Laterales 220 mm



Brevet Europe  
EP-B-2 121 377



Made in  
France



BANQUETTE SUR RAILS COULISSANTS CAMPING-CAR • AUF SCHIENEN VERSCHIEBBARE SITZBANK IM  
WOHNMOBIL • MOTORHOME-SLIDING BENCHSEAT ON RAILS • BANQUETA DESLIZANTE SOBRE RAILES  
AUTOCARAVANA-CAMPER

# ALTAÏR 3P

## SUR RAILS COULISSANTS

- 🇪🇺 BANQUETTE DOUBLE DOSSIER, COUCHAGE COMPLET • CEINTURES 3 POINTS INTÉGRÉES
- 🇩🇪 Sitzbank Zweite Rückenlehne, komplette Schlaf- und Sitzbank. Integrierte Dreipunktgurte
- 🇬🇧 Double Back-Rest Benchseat, Complete Sleeping • Integral 3 Points Belts
- 🇪🇸 Banqueta Doble Respaldo, completo dormir • Cinturones 3 puntos integrados

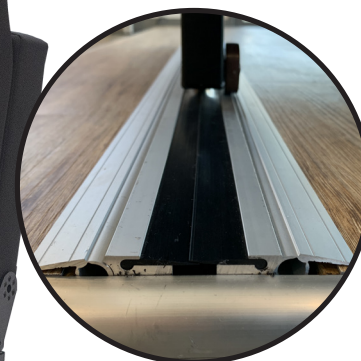
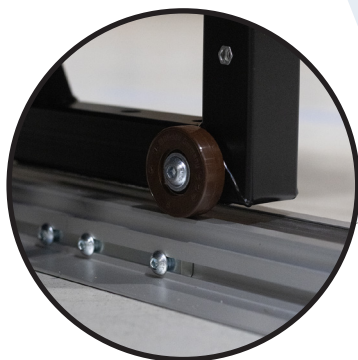



**SCOPEMA**  
RIB SEATING SINCE 1981

**RIB**

## FR CARACTÉRISTIQUES

### Standard



- Homologation européenne et nord américaine
- Mousse «Scopex» Haute Densité
- Largeur des banquettes :
  - 600 mm 
  - 860-940-1040-1120-1200 mm 
  - 1200-1290-1400-1500 mm 
- Houssage matelassé
- Appuis-tête intégrés
- Blocage automatique du dossier en position route
- Système Isofix Top Tether
- Rails coulissants modulables avec verrouillage automatique tous les 25mm
- Méthode 100% collage avec joints intégrés bloquant toute insertion d'impuretés à l'intérieur des rails

### Option

- Accoudoirs relevables intégrés (latéral/central)
- 2ème dossier : 580, 650 ou 730 mm
- Surmatelas 3D intégré côté couchage
- Module de départ de 1150mm (de seulement 8kg). Possibilité d'un rallongement personnalisable avec l'ajout de modules aux choix de :
  - 700 mm
  - 850mm
  - 1000 mm
  - 1150 mm

## DE EIGENSCHAFTEN

### Standard

- EEC Prüfung und Nordamerika
- «Scopex» Schaumstoff mit hoher Raumdichte
- Breite der Bänke :
  - 600 mm 
  - 860-940-1040-1120-1200 mm 
  - 1200-1290-1400-1500 mm 
- Abgestepte Sitzbankbezüge
- Integrierte Kopfstützen
- Automatische Verriegelung der Rückenlehne
- Isofix Top Tether System
- Modulare Gleitschienen mit automatischer Verriegelung alle 25mm
- 100%ige Klebemethode mit integrierten Dichtungen, die das Eindringen von Verunreinigungen in die Schienen verhindern

### Optional

- Integrierte Klappbare Armlehnen (seitlich oder zentral)
- 2. Rückenlehne : 580, 650 oder 730 mm
- Integrierte 3D Schlafpolsterauflage
- 1150-mm-Startmodul (nur 8 kg schwer). Anpassbare Erweiterung durch Module Ihrer Wahl:
  - 700 mm
  - 850mm
  - 1000 mm
  - 1150 mm

## ES CHARACTERISTICS

### Standard



- European and North America Approval
- High Density «Scopex» foam
- Width of the benchseats :
  - 600 mm 
  - 860-940-1040-1120-1200 mm 
  - 1200-1290-1400-1500 mm 
- Quilted seat-covering
- Integrated headrests
- Automatic stoppage of the backrest
- Isofix Top Tether System
- Modular sliding rails with automatic locking every 25mm
- 100% bonding method with integrated gaskets to prevent impurities from penetrating inside the rails

### Option

- Integrated lift-up arm-rest (lateral or central)
- 2nd backrest : 580, 650 or 730 mm
- Integrated 3D mattress overlay (sleeping side)
- 1150mm starter module (weighing only 8kg). Customizable extension with the addition of modules of your choice :
  - 700 mm
  - 850mm
  - 1000 mm
  - 1150 mm

## ES CARACTERÍSTICAS

### Norma

- Homologación Europea y América del norte
- Espuma «Scopex» alta densidad
- Ancho de los asientos :
  - 600 mm 
  - 860-940-1040-1120-1200 mm 
  - 1200-1290-1400-1500 mm 
- Fundas acolchadas
- Reposacabezas integrados
- Bloqueo automático del respaldo
- Sistema Isofix Top Tether
- Guías modulares deslizantes con bloqueo automático cada 25mm
- Método de encolado 100% con juntas integradas para evitar la penetración de impurezas en el interior de los raíles

### Opción

- Reposabrazos móviles integrados (lateral/central)
- Segundo respaldo : 580, 650 o 730 mm
- 3D colchón costado dormir
- Módulo inicial de 1150 mm (sólo pesa 8 kg). Posibilidad de ampliación a medida añadiendo módulos a elegir de :
  - 700 mm
  - 850 mm
  - 1000 mm
  - 1150 mm

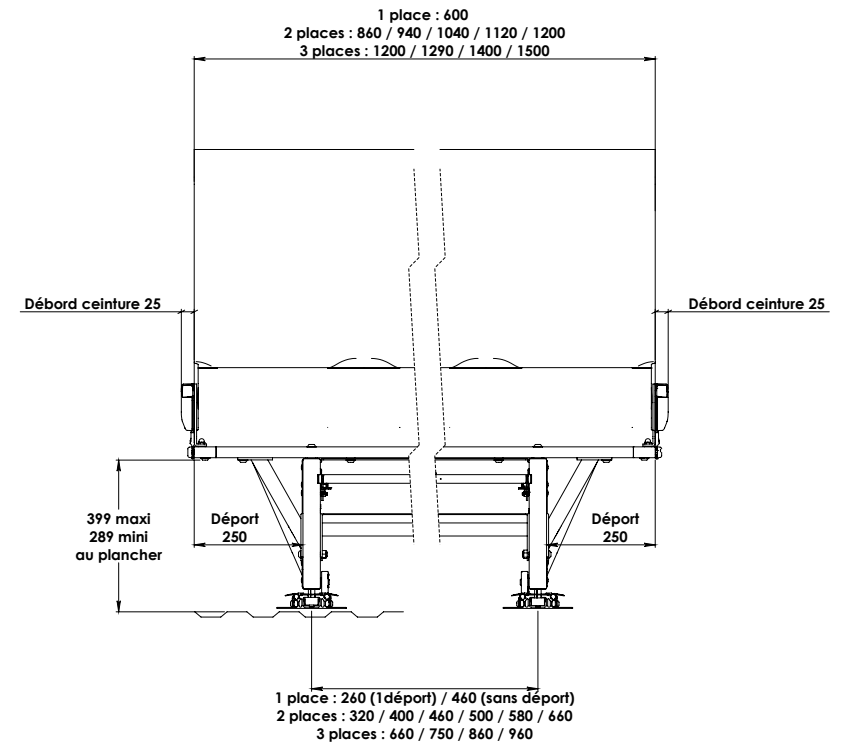
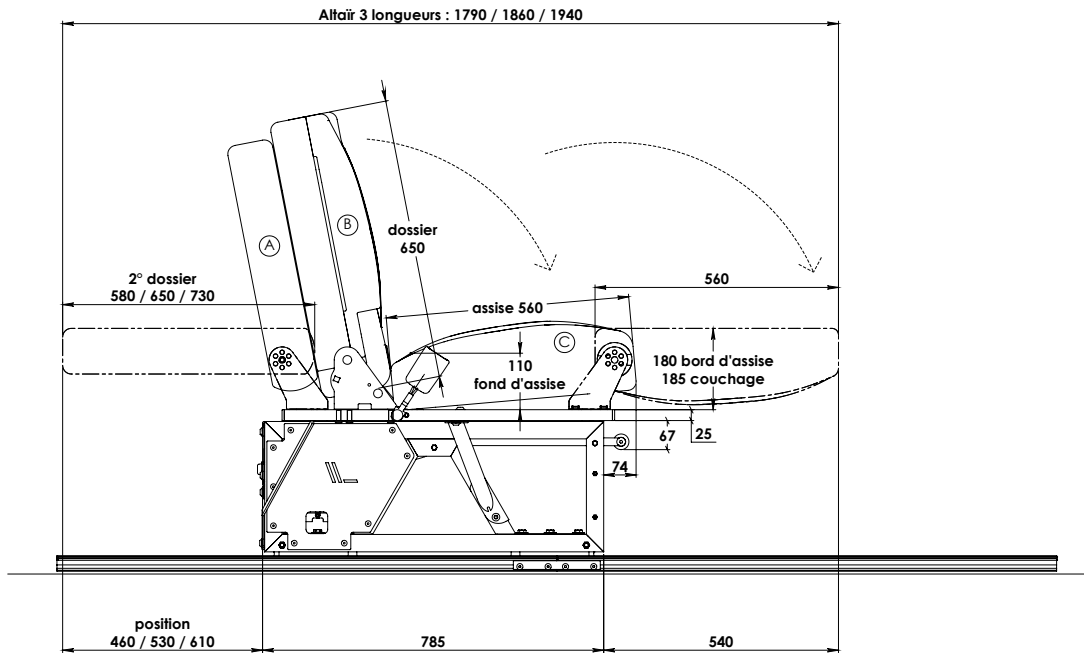

**LÉGENDE**

- A. Dossier arrière
- B. Dossier avec ceintures intégrées
- C. Assise

**LEGENDE**

- A. Hintere Lehne Herunterklappbar zur Bettverlängerung
- B. Rückenlehne mit integrierten Gurten
- C. Sitzfläche

**LEGEND**

- A. Rear Backrest
- B. Backrest with integral belts
- C. Sitting

**LEYENDA**

- A. Expediente posterior
- B. Expediente con cinturones integrados
- C. Base

**Quality - Comfort - Safety**

**Created and manufactured with passion in France for over 40 years**



Brevet Europe  
EP-B-2 121 377



Made in  
France

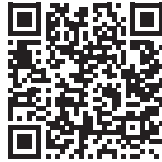

# ALTAÏR 3P SUR RAILS FIXES

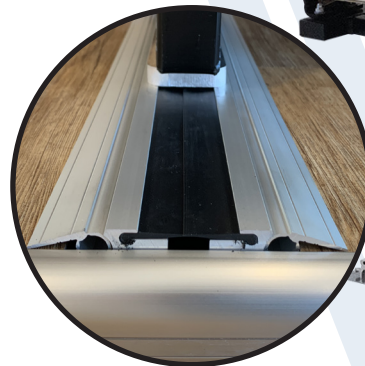

- BANQUETTE DOUBLE DOSSIER, COUCHAGE COMPLET • CEINTURES 3 POINTS INTÉGRÉES
- Sitzbank Zweite Rückenlehne, komplette Schlaf- und Sitzbank. Integrierte Dreipunktgurte
- Double Back-Rest Benchseat, Complete Sleeping • Integral 3 Points Belts
- Banqueta Doble Respaldo, completo dormir • Cinturones 3 puntos integrados





## FR CARACTÉRISTIQUES

### Standard



- Homologation européenne et nord américaine
- Mousse «Scopex» Haute Densité
- Largeur des banquettes :
  - 600 mm 
  - 860-940-1040-1120-1200 mm 
  - 1200-1290-1400-1500 mm 
- Houssage matelassé
- Appuis-tête intégrés
- Blocage automatique du dossier en position route
- Système Isofix Top Tether
- Méthode 100% collage avec joints intégrés bloquant toute insertion d'impuretés à l'intérieur des rails
- Compatible avec plusieurs épaisseurs de plancher : de 19 à 34mm
- Module de rails de 1150mm (de seulement 8kg)

### Option

- Accoudoirs relevables intégrés (latéral/central)
- 2ème dossier : 580, 650 ou 730 mm
- Surmatelas 3D intégré côté couchage

## DE EIGENSCHAFTEN

### Standard

- EEC Prüfung und Nordamerika
- «Scopex» Schaumstoff mit hoher Raumdichte
- Breite der Bänke :
  - 600 mm 
  - 860-940-1040-1120-1200 mm 
  - 1200-1290-1400-1500 mm 
- Abgesteppte Sitzbankbezüge
- Integrierte Kopfstützen
- Automatische Verriegelung der Rückenlehne
- Isofix Top Tether System
- 100%ige Klebemethode mit integrierten Dichtungen, die das Eindringen von Verunreinigungen in die Schienen verhindern
- Kompatibel mit verschiedenen Bodenstärken : von 19 bis 34 mm
- 1150-mm-Schienenmodul (nur 8 kg schwer)

### Optional

- Integrierte Klappbare Armlehnen (seitlich oder zentral)
- 2. Rückenlehne : 580, 650 oder 730 mm
- Integrierte 3D Schlafpolsterauflage

## ES CHARACTERISTICS

### Standard



- European and North America Approval
- High Density «Scopex» foam
- Width of the benchseats :
  - 600 mm 
  - 860-940-1040-1120-1200 mm 
  - 1200-1290-1400-1500 mm 
- Quilted seat-covering
- Integrated headrests
- Automatic stoppage of the backrest
- Isofix Top Tether System
- 100% bonding method with integrated gaskets to prevent impurities from penetrating inside the rails
- Compatible with various floor thicknesses : from 19 to 34 mm
- 1150mm rails module (weighing only 8kg)

### Option

- Integrated lift-up arm-rest (lateral or central)
- 2nd backrest : 580, 650 or 730 mm
- Integrated 3D mattress overlay (sleeping side)

## ES CARACTERÍSTICAS

### Norma

- Homologación Europea y América del norte
- Espuma «Scopex» alta densidad
- Ancho de los asientos :
  - 600 mm 
  - 860-940-1040-1120-1200 mm 
  - 1200-1290-1400-1500 mm 
- Fundas acolchadas
- Reposacabezas integrados
- Bloqueo automático del respaldo
- Sistema Isofix Top Tether
- Método de encolado 100% con juntas integradas para evitar la penetración de impurezas en el interior de los raíles
- Compatible con varios grosores de suelo : de 19 a 34 mm
- Módulo de raíles de 1150 mm (sólo pesa 8 kg)

### Opción

- Reposabrazos móviles integrados (lateral/central)
- Segundo respaldo : 580, 650 o 730 mm
- 3D colchón costado dormir

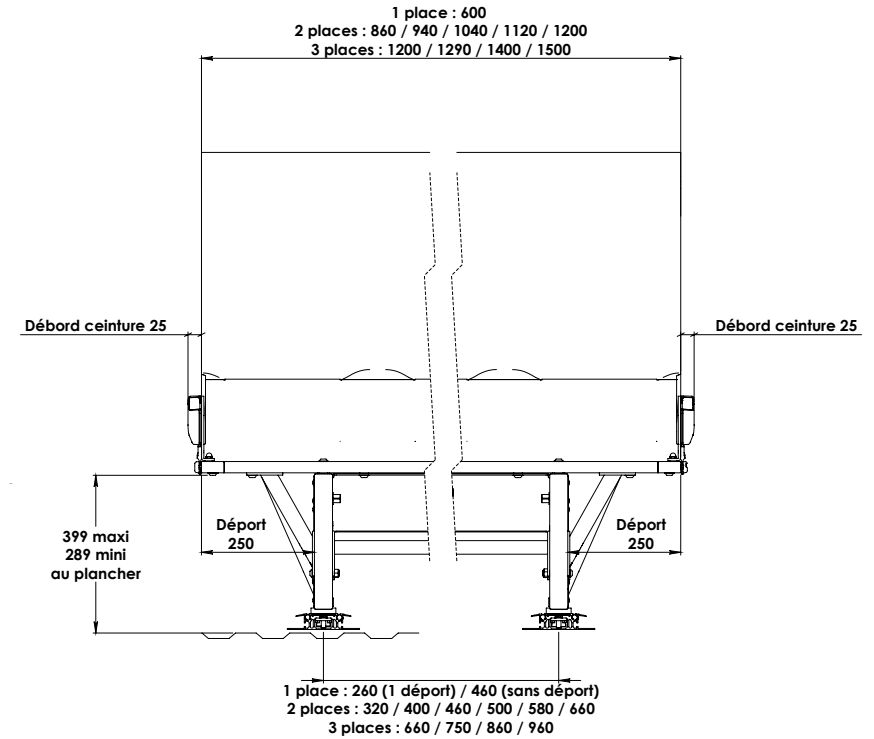
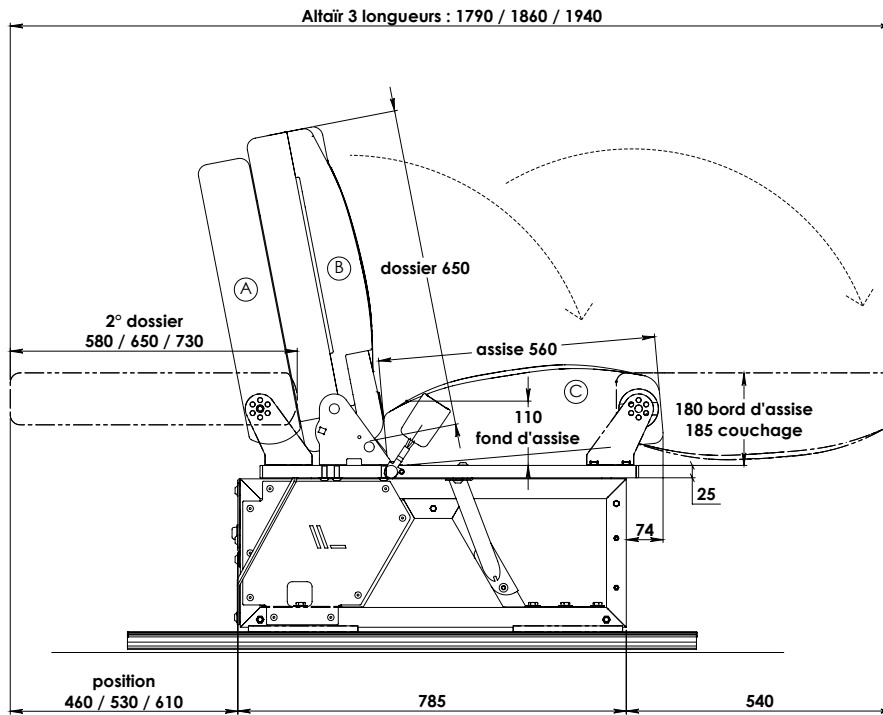

LÉGENDE

- A. Dossier arrière
- B. Dossier avec ceintures intégrées
- C. Assise

LEGENDE

- A. Hintere Lehne Herunterklappbar zur Bettverlängerung
- B. Rückenlehne mit integrierten Gurten
- C. Sitzfläche

LEGEND

- A. Rear Backrest
- B. Backrest with integral belts
- C. Sitting

LEYENDA

- A. Expediente posterior
- B. Expediente con cinturones integrados
- C. Base

**Quality - Comfort - Safety**

**Created and manufactured with passion in France for over 40 years**



Brevet Europe  
EP-B-2 121 377



Made in  
France



Modèle avec accoudoirs intégrés  
et repose-tête grande largeur.  
Plusieurs solutions d'aménagement possibles.



Banquette 2 places



2 banquettes 1 place



En couchage avec  
les sièges avant retournés

# NEPTUNE 3P

ASSISE ET DOSSIER GALBÉS, COUCHAGE PLAT • CEINTURES 3 POINTS INTÉGRÉES

- Ergonomisch geformte Sitz- und Rückenflächen • Ebene Schlaffläche  
Integrierte Dreipunktgurte
- Curved back and sitting, flat sleeping • Integral 3 Points Belts
- Base y expediente doblada, capa plana • Cinturones 3 puntos integrados



# NEPTUNE 3P

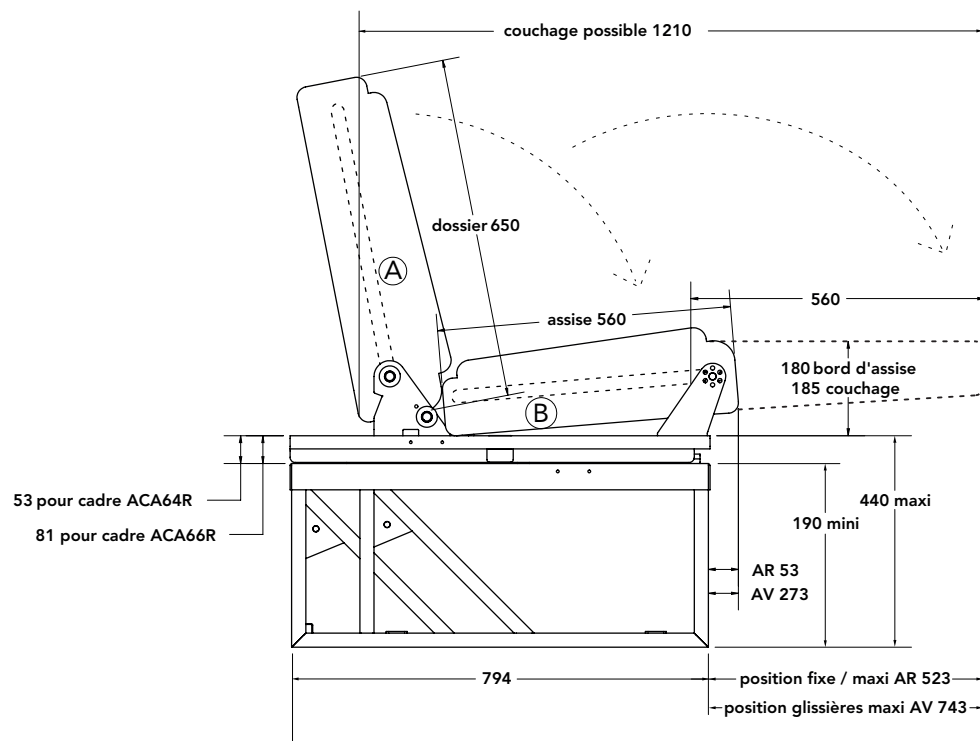

## LÉGENDE

- A. Dossier avec ceintures intégrées
- B. Assise

## LEGENDE

- A. Rückenlehne mit integrierten Gurten
- B. Sitzfläche

## LEGEND

- A. Back-rest with integral belts
- B. Sitting

## LEYENDA

- A. Expediente con cinturones integrados
- B. Base

## CARACTÉRISTIQUES

### Standard

- Homologation européenne
- Mousse «Scopex» Haute Densité
- Largeur des banquettes :
  - 600 mm
  - 860 - 940 - 1040 - 1120 - 1200 mm
  - 1200 - 1290 - 1400 - 1500 mm
- Houssage matelassé
- Blocage automatique du dossier en position route
- Système Isofix Top Tether

### Option

- Appuis-tête intégrés
- Accoudoirs relevables intégrés (latéral/central)
- Glissières
  - Longitudinales 220 mm
  - Latérales 220 mm
- Surmatelas 3D intégré côté couchage

## EIGENSCHAFTEN

### Standard

- EEC Prüfung
- «Scopex» Schaumstoff mit hoher Raumdichte
- Breite der Bänke :
  - 600 mm
  - 860 - 940 - 1040 - 1120 - 1200 mm
  - 1200 - 1290 - 1400 - 1500 mm
- Abgesteppte Sitzbankbezüge
- Automatische Verriegelung der Rückenlehne
- Isofix Top Tether System

### Optional

- Integrierte kopfstützen
- Integrierte Klappbare Armlehnen (seitlich oder zentral)
- Führungsschienen zwischen Unterbock und Polsterung für
  - Längsverschiebung 220 mm
  - Querverschiebung 220 mm
- Integrierte 3D Schlafpolsterauflage

## CHARACTERISTICS

### Standard

- European Approval
- High Density «Scopex» foam
- Width of the benchseats :
  - 600 mm
  - 860 - 940 - 1040 - 1120 - 1200 mm
  - 1200 - 1290 - 1400 - 1500 mm
- Quilted seat-covering
- Automatic stoppage of the backrest
- Isofix Top Tether System

### Option

- Integrated headrests
- Integrated lift-up arm-rest (lateral or central)
- Slides
  - 220 mm lengthwise
  - 220 mm lateral
- Integrated 3D mattress overlay (sleeping side)

## CARACTERÍSTICAS

### Norma

- Homologación Europea
- Espuma «Scopex» alta densidad
- Ancho de los asientos :
  - 600 mm
  - 860 - 940 - 1040 - 1120 - 1200 mm
  - 1200 - 1290 - 1400 - 1500 mm
- Enfundadura acolchada
- Bloqueo automático del expediente en posición carretera
- Sistema Isofix Top Tether

### Opción

- Reposacabezas integrados
- Apoya Brazos móviles integrados (lateral/central)
- Correderas
  - Longitudinales 220 mm
  - Laterales 220 mm
- Surmatelas 3D integrada numerada capa



Brevet Europe  
EP-B-2 121 377



Made in  
France



# NEPTUNE 3P SUR RAILS COULISSANTS

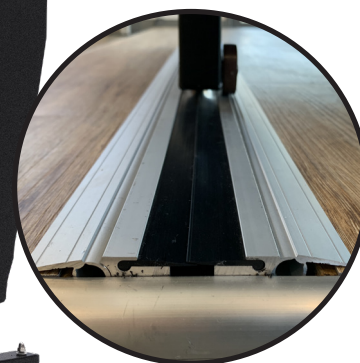
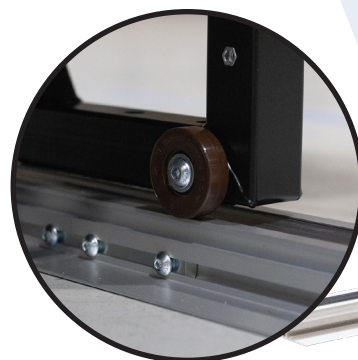

- 🇫🇷 ASSISE ET DOSSIER GALBÉS, COUCHAGE PLAT • CEINTURES 3 POINTS INTÉGRÉES
- 🇩🇪 Ergonomisch geformte Sitz- und Rückenflächen • Ebene Schlaflfläche Integrierte Dreipunktgurte
- 🇬🇧 Curved back and sitting, flat sleeping • Integral 3 Points Belts
- 🇪🇸 Base y expediente doblada, capa plana • Cinturones 3 puntos integrados



**SCOPEMA**  
RIB SEATING SINCE 1981

**RIB**



Standard

- Homologation européenne et nord américaine
- Mousse «Scopex» Haute Densité
- Largeur des banquettes :
  - 600 mm 
  - 860-940-1040-1120-1200 mm 
  - 1200-1290-1400-1500 mm 
- Houssage matelassé
- Appuis-tête intégrés
- Blocage automatique du dossier en position route
- Système Isofix Top Tether
- Rails coulissants modulables avec verrouillage automatique tous les 25mm
- Méthode 100% collage avec joints intégrés bloquant toute insertion d'impuretés à l'intérieur des rails

Option

- Accoudoirs relevables intégrés (latéral/central)
- Surmatelas 3D intégré côté couchage
- Module de départ de 1150mm (de seulement 8kg). Possibilité d'un rallongement personnalisable avec l'ajout de modules aux choix de :
  - 700 mm
  - 850mm
  - 1000 mm
  - 1150 mm

Standard

- EEC Prüfung und Nordamerika
- «Scopex» Schaumstoff mit hoher Raumdichte
- Breite der Bänke :
  - 600 mm 
  - 860-940-1040-1120-1200 mm 
  - 1200-1290-1400-1500 mm 
- Abgestepte Sitzbankbezüge
- Integrierte Kopfstützen
- Automatische Verriegelung der Rückenlehne
- Isofix Top Tether System
- Modulare Gleitschienen mit automatischer Verriegelung alle 25mm
- 100%ige Klebemethode mit integrierten Dichtungen, die das Eindringen von Verunreinigungen in die Schienen verhindern

Optional

- Integrierte Klappbare Armlehnen (seitlich oder zentral)
- Integrierte 3D Schlafpolsterauflage
- 1150-mm-Startmodul (nur 8 kg schwer). Anpassbare Erweiterung durch Module Ihrer Wahl:
  - 700 mm
  - 850mm
  - 1000 mm
  - 1150 mm



Standard

- European and North America Approval
- High Density «Scopex» foam
- Width of the benchseats :
  - 600 mm 
  - 860-940-1040-1120-1200 mm 
  - 1200-1290-1400-1500 mm 
- Quilted seat-covering
- Integrated headrests
- Automatic stoppage of the backrest
- Isofix Top Tether System
- Modular sliding rails with automatic locking every 25mm
- 100% bonding method with integrated gaskets to prevent impurities from penetrating inside the rails

Option

- Integrated lift-up arm-rest (lateral or central)
- Integrated 3D mattress overlay (sleeping side)
- 1150mm starter module (weighing only 8kg). Customizable extension with the addition of modules of your choice :
  - 700 mm
  - 850mm
  - 1000 mm
  - 1150 mm

Norma

- Homologación Europea y América del norte
- Espuma «Scopex» alta densidad
- Ancho de los asientos :
  - 600 mm 
  - 860-940-1040-1120-1200 mm 
  - 1200-1290-1400-1500 mm 
- Fundas acolchadas
- Reposacabezas integrados
- Bloqueo automático del respaldo
- Sistema Isofix Top Tether
- Guías modulares deslizantes con bloqueo automático cada 25mm
- Método de encolado 100% con juntas integradas para evitar la penetración de impurezas en el interior de los raíles

Opción

- Reposabrazos móviles integrados (lateral/central)
- 3D colchón costado dormir
- Módulo inicial de 1150 mm (sólo pesa 8 kg). Posibilidad de ampliación a medida añadiendo módulos a elegir de :
  - 700 mm
  - 850 mm
  - 1000 mm
  - 1150 mm

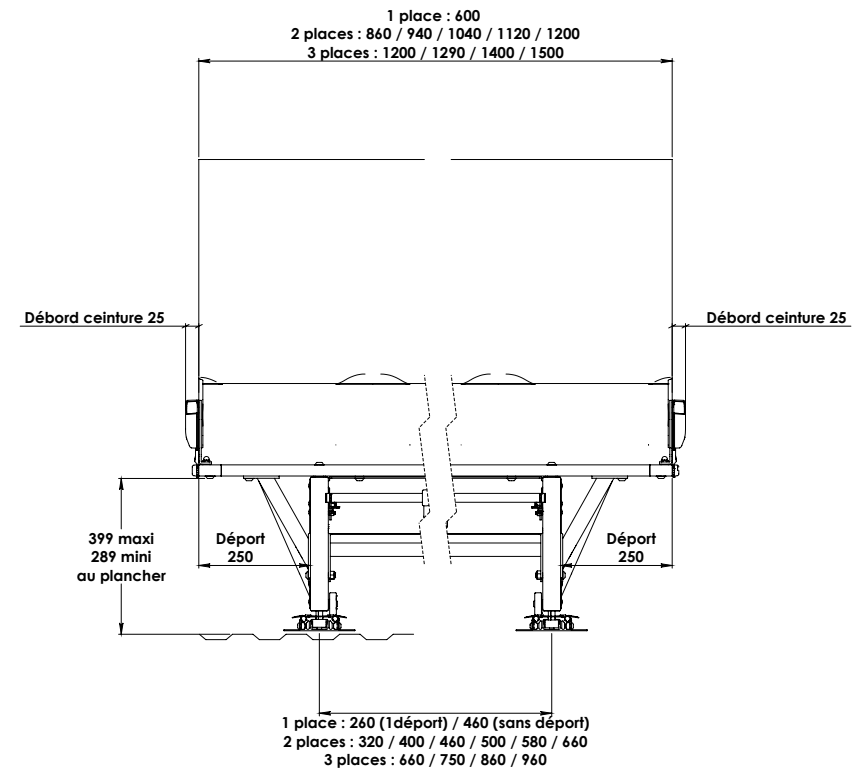
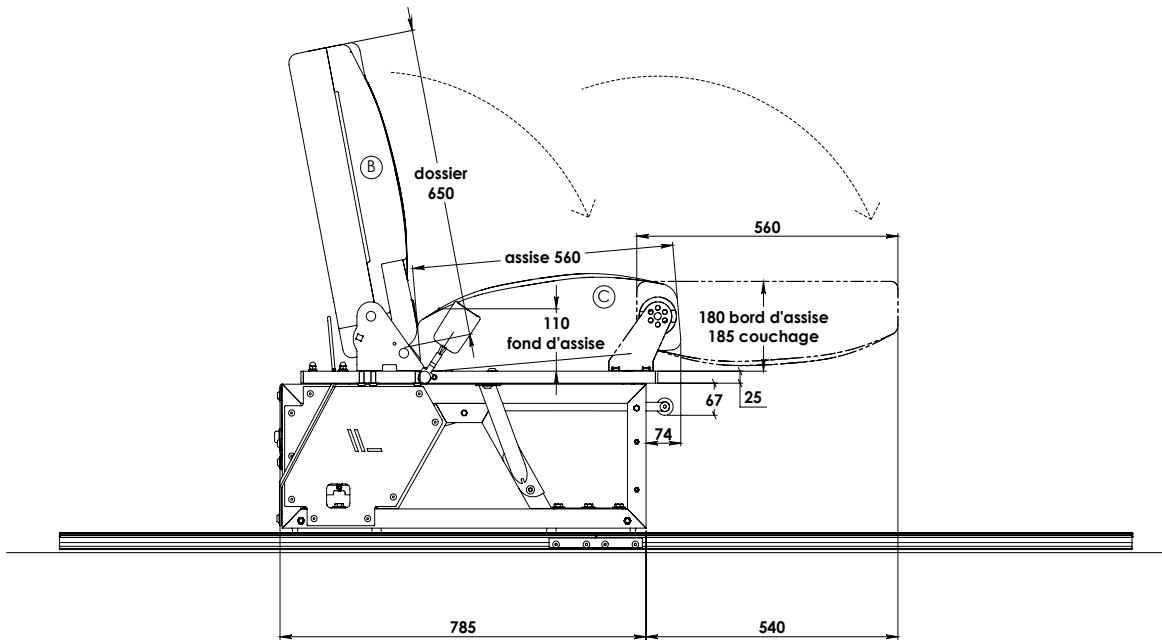

LÉGENDE

- B. Dossier avec ceintures intégrées
- C. Assise

LEGENDE

- B. Rückenlehne mit integrierten Gurten
- C. Sitzfläche

LEGEND

- B. Backrest with integral belts
- C. Sitting

LEYENDA

- B. Expediente con cinturones integrados
- C. Base

**Quality - Comfort - Safety**

Created and manufactured with  
passion in France for over 40 years



Brevet Europe  
EP-B-2 121 377



Made in  
France

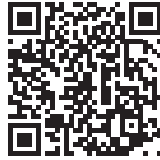

# NEPTUNE 3P SUR RAILS FIXES

- ASSISE ET DOSSIER GALBÉS, COUCHAGE PLAT • CEINTURES 3 POINTS INTÉGRÉES
- Ergonomisch geformte Sitz- und Rückenflächen • Ebene Schlaffläche Integrierte Dreipunktgurte
- Curved back and sitting, flat sleeping • Integral 3 Points Belts
- Base y expediente doblada, capa plana • Cinturones 3 puntos integrados

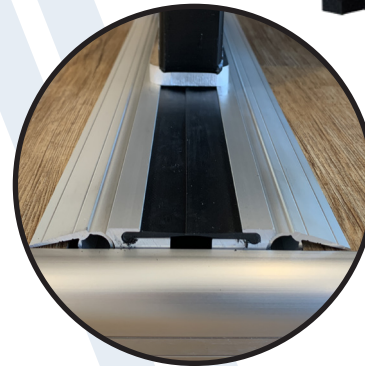



**SCOPEMA**  
RIB SEATING SINCE 1981

**RIB**



## CARACTÉRISTIQUES

### Standard

- Homologation européenne et nord américaine
- Mousse «Scopex» Haute Densité
- Largeur des banquettes :
  - 600 mm 
  - 860-940-1040-1120-1200 mm 
  - 1200-1290-1400-1500 mm 
- Houssage matelassé
- Appuis-tête intégrés
- Blocage automatique du dossier en position route
- Système Isofix Top Tether
- Méthode 100% collage avec joints intégrés bloquant toute insertion d'impuretés à l'intérieur des rails
- Compatible avec plusieurs épaisseurs de plancher : de 19 à 34mm
- Module de rails de 1150mm (de seulement 8kg)

### Option

- Accoudoirs relevables intégrés (latéral/central)
- Surmatelas 3D intégré côté couchage

## CHARACTERISTICS

### Standard



- European and North America Approval
- High Density «Scopex» foam
- Width of the benchseats :
  - 600 mm 
  - 860-940-1040-1120-1200 mm 
  - 1200-1290-1400-1500 mm 
- Quilted seat-covering
- Integrated headrests
- Automatic stoppage of the backrest
- Isofix Top Tether System
- 100% bonding method with integrated gaskets to prevent impurities from penetrating inside the rails
- Compatible with various floor thicknesses : from 19 to 34 mm
- 1150mm rails module (weighing only 8kg)

### Option

- Integrated lift-up arm-rest (lateral or central)
- Integrated 3D mattress overlay (sleeping side)

## EIGENSCHAFTEN

### Standard



- EEC Prüfung und Nordamerika
- «Scopex» Schaumstoff mit hoher Raumdichte
- Breite der Bänke :
  - 600 mm 
  - 860-940-1040-1120-1200 mm 
  - 1200-1290-1400-1500 mm 
- Abgesteppte Sitzbankbezüge
- Integrierte Kopfstützen
- Automatische Verriegelung der Rückenlehne
- Isofix Top Tether System
- 100%ige Klebmethode mit integrierten Dichtungen, die das Eindringen von Verunreinigungen in die Schienen verhindern
- Kompatibel mit verschiedenen Bodenstärken : von 19 bis 34 mm
- 1150-mm-Schienenmodul (nur 8 kg schwer)

### Optional

- Integrierte Klappbare Armlehnen (seitlich oder zentral)
- Integrierte 3D Schlafpolsterauflage

## CARACTERÍSTICAS

### Norma

- Homologación Europea y América del norte
- Espuma «Scopex» alta densidad
- Ancho de los asientos :
  - 600 mm 
  - 860-940-1040-1120-1200 mm 
  - 1200-1290-1400-1500 mm 
- Fundas acolchadas
- Reposacabezas integrados
- Bloqueo automático del respaldo
- Sistema Isofix Top Tether
- Método de encolado 100% con juntas integradas para evitar la penetración de impurezas en el interior de los raíles
- Compatible con varios grosores de suelo : de 19 a 34 mm
- Módulo de raíles de 1150 mm (sólo pesa 8 kg)

### Opción

- Reposabrazos móviles integrados (lateral/central)
- 3D colchón costado dormir

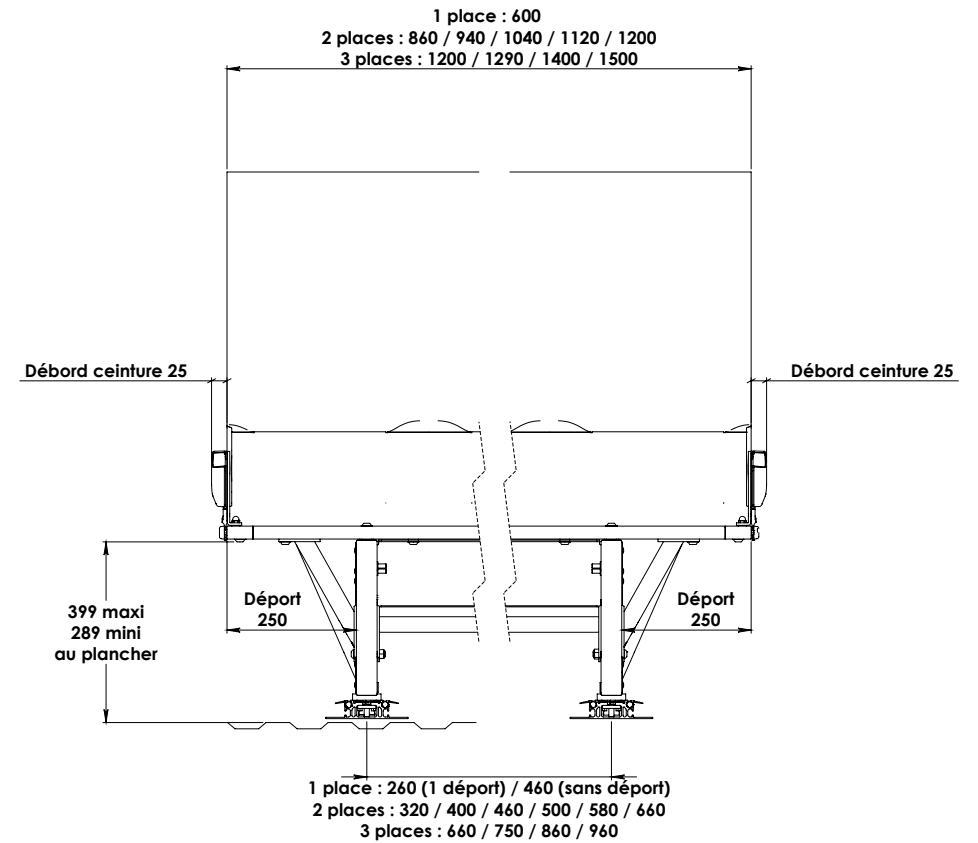
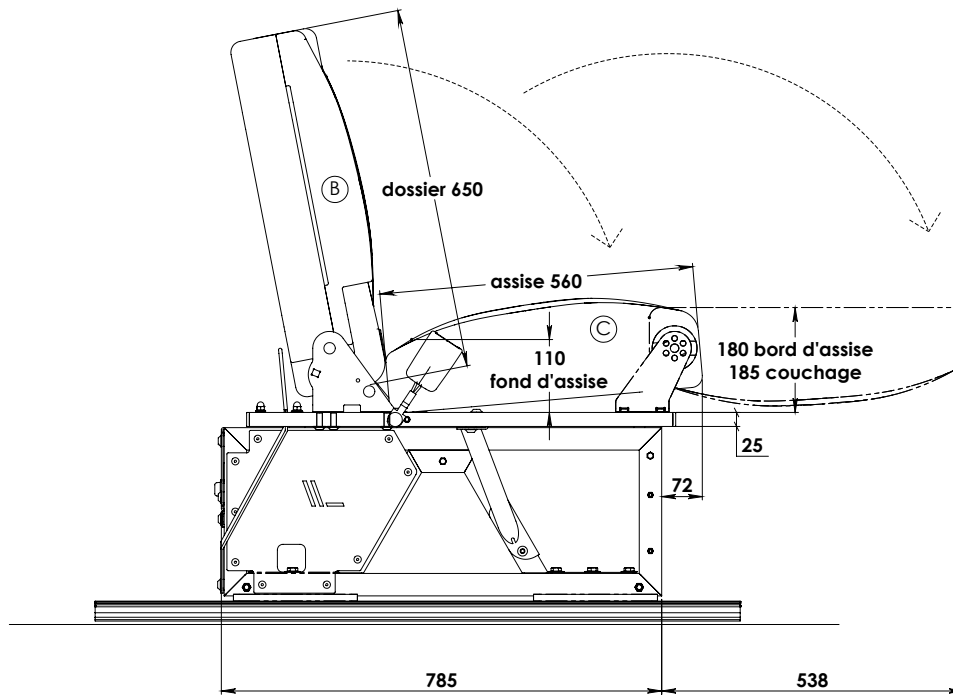

**LÉGENDE**

- B. Dossier avec ceintures intégrées
- C. Assise

**LEGENDE**

- B. Rückenlehne mit integrierten Gurten
- C. Sitzfläche

**LEGEND**

- B. Backrest with integral belts
- C. Sitting

**LEYENDA**

- B. Expediente con cinturones integrados
- C. Base

**Quality - Comfort - Safety**

**Created and manufactured with  
passion in France for over 40 years**