



Brevet Europe
EP-B-2 121 377



Made in
France



NEPTUNE 3P SUR RAILS COULISSANTS

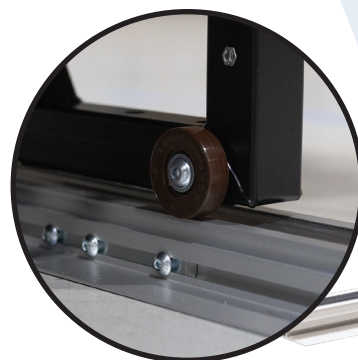

- 🇫🇷 ASSISE ET DOSSIER GALBÉS, COUCHAGE PLAT • CEINTURES 3 POINTS INTÉGRÉES
- 🇩🇪 Ergonomisch geformte Sitz- und Rückenflächen • Ebene Schlaflfläche Integrierte Dreipunktgurte
- 🇬🇧 Curved back and sitting, flat sleeping • Integral 3 Points Belts
- 🇪🇸 Base y expediente doblada, capa plana • Cinturones 3 puntos integrados



SCOPEMA
RIB SEATING SINCE 1981

RIB



Standard

- Homologation européenne et nord américaine
- Mousse «Scopex» Haute Densité
- Largeur des banquettes :
 - 600 mm 
 - 860-940-1040-1120-1200 mm 
 - 1200-1290-1400-1500 mm 
- Houssage matelassé
- Appuis-tête intégrés
- Blocage automatique du dossier en position route
- Système Isofix Top Tether
- Rails coulissants modulables avec verrouillage automatique tous les 25mm
- Méthode 100% collage avec joints intégrés bloquant toute insertion d'impuretés à l'intérieur des rails

Option

- Accoudoirs relevables intégrés (latéral/central)
- Surmatelas 3D intégré côté couchage
- Module de départ de 1150mm (de seulement 8kg). Possibilité d'un rallongement personnalisable avec l'ajout de modules aux choix de :
 - 700 mm
 - 850mm
 - 1000 mm
 - 1150 mm

Standard

- EEC Prüfung und Nordamerika
- «Scopex» Schaumstoff mit hoher Raumdichte
- Breite der Bänke :
 - 600 mm 
 - 860-940-1040-1120-1200 mm 
 - 1200-1290-1400-1500 mm 
- Abgestepte Sitzbankbezüge
- Integrierte Kopfstützen
- Automatische Verriegelung der Rückenlehne
- Isofix Top Tether System
- Modulare Gleitschienen mit automatischer Verriegelung alle 25mm
- 100%ige Klebemethode mit integrierten Dichtungen, die das Eindringen von Verunreinigungen in die Schienen verhindern

Optional

- Integrierte Klappbare Armlehnen (seitlich oder zentral)
- Integrierte 3D Schlafpolsterauflage
- 1150-mm-Startmodul (nur 8 kg schwer). Anpassbare Erweiterung durch Module Ihrer Wahl:
 - 700 mm
 - 850mm
 - 1000 mm
 - 1150 mm



Standard

- European and North America Approval
- High Density «Scopex» foam
- Width of the benchseats :
 - 600 mm 
 - 860-940-1040-1120-1200 mm 
 - 1200-1290-1400-1500 mm 
- Quilted seat-covering
- Integrated headrests
- Automatic stoppage of the backrest
- Isofix Top Tether System
- Modular sliding rails with automatic locking every 25mm
- 100% bonding method with integrated gaskets to prevent impurities from penetrating inside the rails

Option

- Integrated lift-up arm-rest (lateral or central)
- Integrated 3D mattress overlay (sleeping side)
- 1150mm starter module (weighing only 8kg). Customizable extension with the addition of modules of your choice :
 - 700 mm
 - 850mm
 - 1000 mm
 - 1150 mm

Norma

- Homologación Europea y América del norte
- Espuma «Scopex» alta densidad
- Ancho de los asientos :
 - 600 mm 
 - 860-940-1040-1120-1200 mm 
 - 1200-1290-1400-1500 mm 
- Fundas acolchadas
- Reposacabezas integrados
- Bloqueo automático del respaldo
- Sistema Isofix Top Tether
- Guías modulares deslizantes con bloqueo automático cada 25mm
- Método de encolado 100% con juntas integradas para evitar la penetración de impurezas en el interior de los raíles

Opción

- Reposabrazos móviles integrados (lateral/central)
- 3D colchón costado dormir
- Módulo inicial de 1150 mm (sólo pesa 8 kg). Posibilidad de ampliación a medida añadiendo módulos a elegir de :
 - 700 mm
 - 850 mm
 - 1000 mm
 - 1150 mm

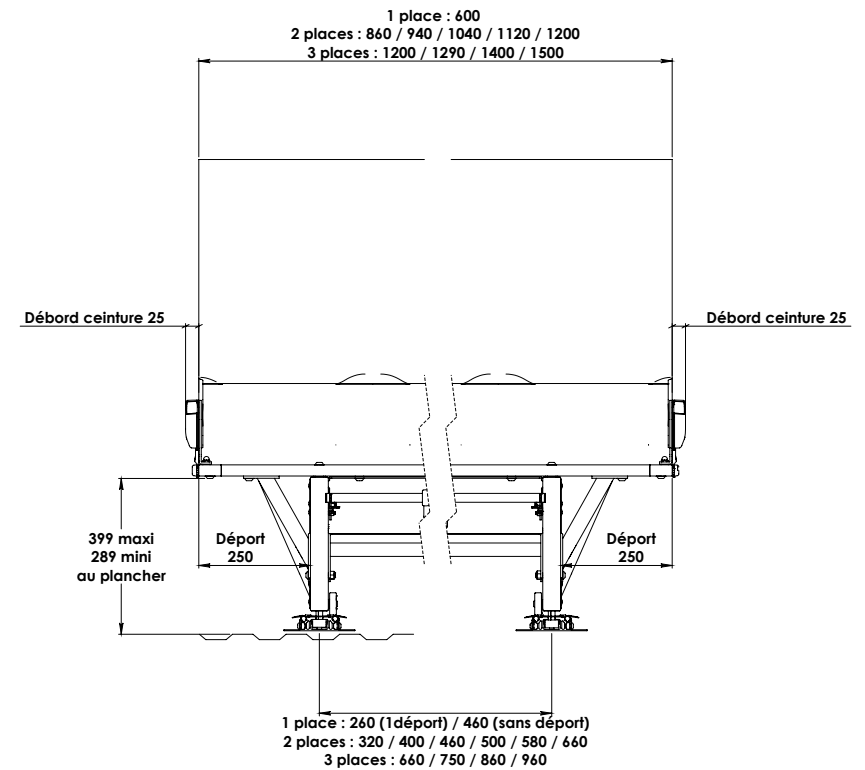
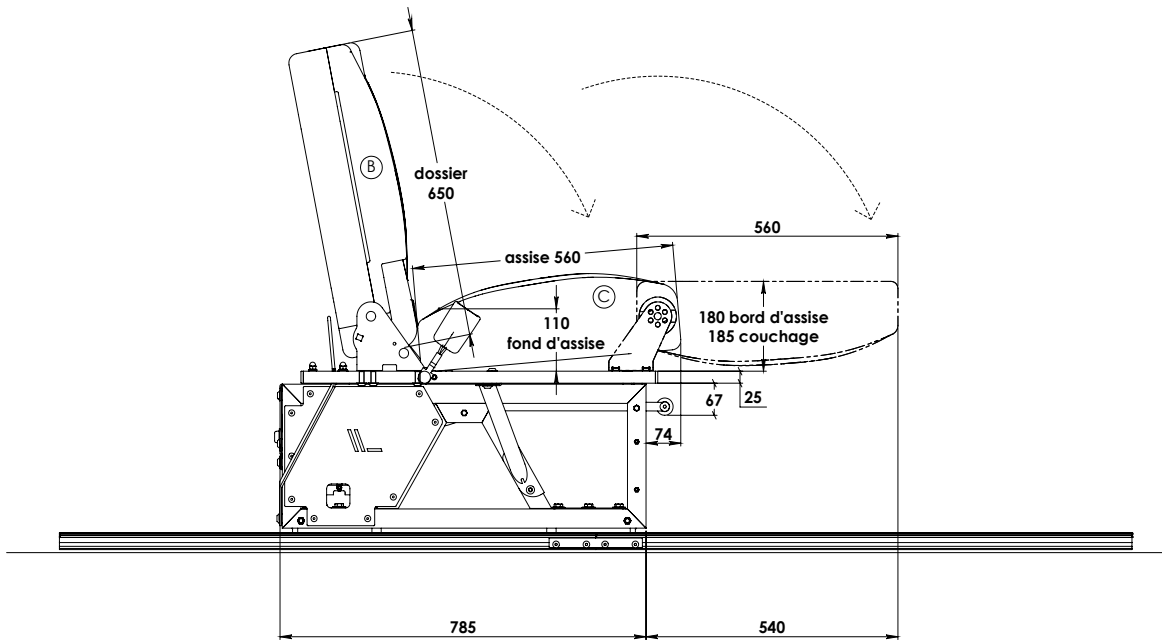

LÉGENDE

- B. Dossier avec ceintures intégrées
- C. Assise

LEGENDE

- B. Rückenlehne mit integrierten Gurten
- C. Sitzfläche

LEGEND

- B. Backrest with integral belts
- C. Sitting

LEYENDA

- B. Expediente con cinturones integrados
- C. Base

Quality - Comfort - Safety

Created and manufactured with
passion in France for over 40 years