



Brevet Europe
EP-B-2 121 377



Made in
France



ALTAÏR 3P

- DOUBLE DOSSIER, COUCHAGE COMPLET • CEINTURES 3 POINTS INTÉGRÉES
- Zweite Rückenlehne, komplette Schlaf- und Sitzbank. Integrierte Dreipunktgurte
- Double Back-Rest, Complete Sleeping • Integral 3 Points Belts
- Doble Respaldo, completo dormir • Cinturones 3 puntos integrados



Banquette 3 places



Banquette 2 places



Positions de couchage



ALTAÏR 3P

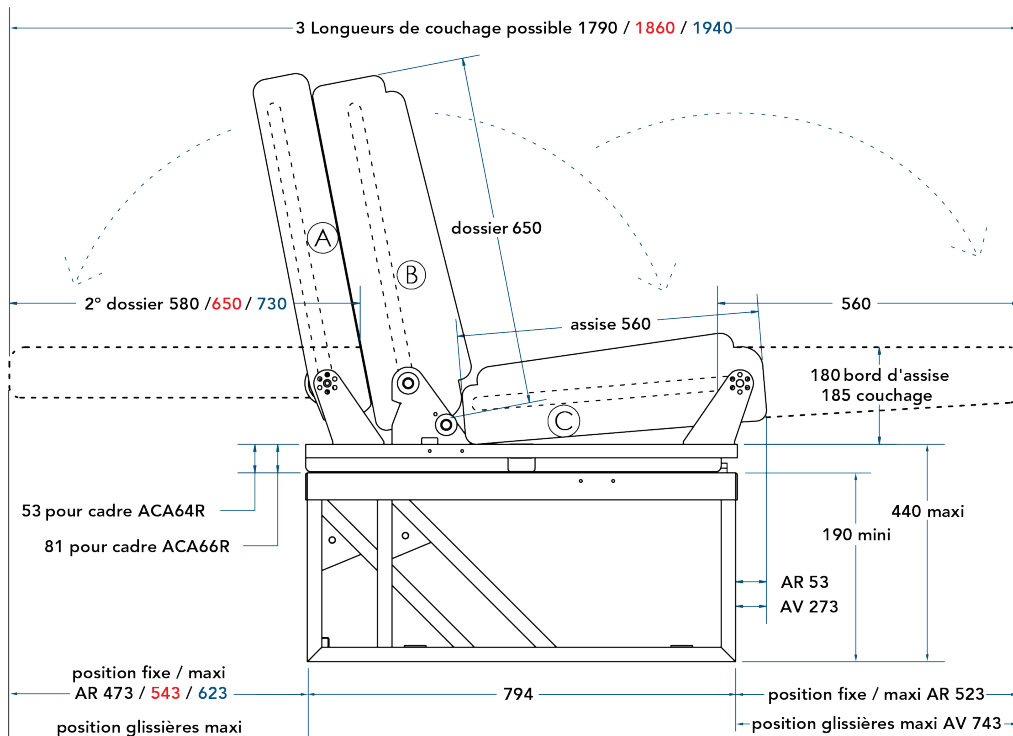

LÉGENDE

- A. Dossier arrière
- B. Dossier avec ceintures intégrées
- C. Assise

LEGEND

- A. Rear Backrest
- B. Backrest with integral belts
- C. Sitting

LEGENDE

- A. Hintere Lehne Herunterklappbar zur Bettverlängerung
- B. Rückenlehne mit integrierten Gurten
- C. Sitzfläche

LEYENDA

- A. Expediente posterior
- B. Expediente con cinturones integrados
- C. Base

CARACTÉRISTIQUES

Standard

- Homologation européenne
- Mousse «Scopex» Haute Densité
- Largeur des banquettes :
 - 600 mm
 - 860-940-1040-1120-1200 mm
 - 1200-1290-1400-1500 mm
- Houssage matelassé
- Blocage automatique du dossier en position route
- Système Isofix Top Tether

Option

- Appuis-tête intégrés
- Accoudoirs relevables intégrés (latéral/central)
- 2ème dossier 580 ou 730 mm (au lieu de 650)
- Surmatelas 3D intégré côté couchage
- Glissières
 - Longitudinales 220 mm
 - Latérales 220 mm

CHARACTERISTICS

Standard

- European Approval
- High Density «Scopex» foam
- Width of the benchseats :
 - 600 mm
 - 860-940-1040-1120-1200 mm
 - 1200-1290-1400-1500 mm
- Quilted seat-covering
- Automatic stoppage of the backrest
- Isofix Top Tether System

Option

- Integrated headrests
- Integrated lift-up arm-rest (lateral or central)
- 2nd backrest 580 or 730 mm (instead of 650 mm)
- Integrated 3D mattress overlay (sleeping side)
- Sliders
 - 220 mm lengthwise
 - 220 mm lateral

EIGENSCHAFTEN

Standard

- EEC Prüfung
- «Scopex» Schaumstoff mit hoher Raumdichte
- Breite der Bänke :
 - 600 mm
 - 860-940-1040-1120-1200 mm
 - 1200-1290-1400-1500 mm
- Abgesteppte Sitzbankbezüge
- Automatische Verriegelung der Rückenlehne
- Isofix Top Tether System

Optional

- Integrierte Kopfstützen
- Integrierte Klappbare Armlehnen (seitlich oder zentral)
- Hintere Lehne. Herunterklappbar zur Bettverlängerung 580 oder 730 mm (statt 650 mm)
- Integrierte 3D Schlafpolsterauflage
- Führungsschienen zwischen Unterbock und Polsterung für
 - 220 mm Längsverschiebung
 - 220 mm Querverschiebung

CARACTERÍSTICAS

Norma

- Homologación Europea
- Espuma «Scopex» alta densidad
- Ancho de los asientos :
 - 600 mm
 - 860-940-1040-1120-1200 mm
 - 1200-1290-1400-1500 mm
- Fundas acolchadas
- Bloqueo automático del respaldo
- Sistema Isofix Top Tether

Opción

- Reposacabezas integrados
- Reposabrazos móviles integrados (lateral/central)
- Segundo respaldo 580 o 730 mm (al lugar de 650 mm)
- 3D colchón costado dormir
- Guías correderas
 - Longitudinales 220 mm
 - Laterales 220 mm



Brevet Europe
EP-B-2 121 377



Made in
France

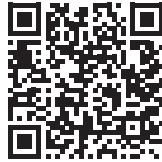

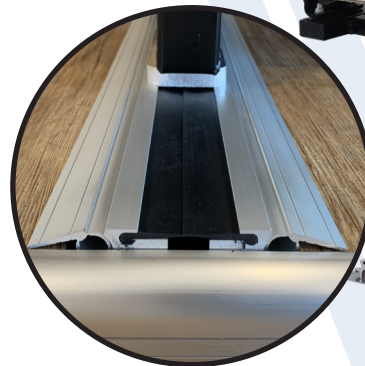

ALTAÏR 3P SUR RAILS FIXES

- BANQUETTE DOUBLE DOSSIER, COUCHAGE COMPLET • CEINTURES 3 POINTS INTÉGRÉES
- Sitzbank Zweite Rückenlehne, komplette Schlaf- und Sitzbank. Integrierte Dreipunktgurte
- Double Back-Rest Benchseat, Complete Sleeping • Integral 3 Points Belts
- Banqueta Doble Respaldo, completo dormir • Cinturones 3 puntos integrados



FR CARACTÉRISTIQUES

Standard



- Homologation européenne et nord américaine
- Mousse «Scopex» Haute Densité
- Largeur des banquettes :
 - 600 mm 
 - 860-940-1040-1120-1200 mm 
 - 1200-1290-1400-1500 mm 
- Houssage matelassé
- Appuis-tête intégrés
- Blocage automatique du dossier en position route
- Système Isofix Top Tether
- Méthode 100% collage avec joints intégrés bloquant toute insertion d'impuretés à l'intérieur des rails
- Compatible avec plusieurs épaisseurs de plancher : de 19 à 34mm
- Module de rails de 1150mm (de seulement 8kg)

Option

- Accoudoirs relevables intégrés (latéral/central)
- 2ème dossier : 580, 650 ou 730 mm
- Surmatelas 3D intégré côté couchage

DE EIGENSCHAFTEN

Standard

- EEC Prüfung und Nordamerika
- «Scopex» Schaumstoff mit hoher Raumdichte
- Breite der Bänke :
 - 600 mm 
 - 860-940-1040-1120-1200 mm 
 - 1200-1290-1400-1500 mm 
- Abgesteppte Sitzbankbezüge
- Integrierte Kopfstützen
- Automatische Verriegelung der Rückenlehne
- Isofix Top Tether System
- 100%ige Klebemethode mit integrierten Dichtungen, die das Eindringen von Verunreinigungen in die Schienen verhindern
- Kompatibel mit verschiedenen Bodenstärken : von 19 bis 34 mm
- 1150-mm-Schienenmodul (nur 8 kg schwer)

Optional

- Integrierte Klappbare Armlehnen (seitlich oder zentral)
- 2. Rückenlehne : 580, 650 oder 730 mm
- Integrierte 3D Schlafpolsterauflage

ES CHARACTERISTICS

Standard



- European and North America Approval
- High Density «Scopex» foam
- Width of the benchseats :
 - 600 mm 
 - 860-940-1040-1120-1200 mm 
 - 1200-1290-1400-1500 mm 
- Quilted seat-covering
- Integrated headrests
- Automatic stoppage of the backrest
- Isofix Top Tether System
- 100% bonding method with integrated gaskets to prevent impurities from penetrating inside the rails
- Compatible with various floor thicknesses : from 19 to 34 mm
- 1150mm rails module (weighing only 8kg)

Option

- Integrated lift-up arm-rest (lateral or central)
- 2nd backrest : 580, 650 or 730 mm
- Integrated 3D mattress overlay (sleeping side)

ES CARACTERÍSTICAS

Norma

- Homologación Europea y América del norte
- Espuma «Scopex» alta densidad
- Ancho de los asientos :
 - 600 mm 
 - 860-940-1040-1120-1200 mm 
 - 1200-1290-1400-1500 mm 
- Fundas acolchadas
- Reposacabezas integrados
- Bloqueo automático del respaldo
- Sistema Isofix Top Tether
- Método de encolado 100% con juntas integradas para evitar la penetración de impurezas en el interior de los raíles
- Compatible con varios grosores de suelo : de 19 a 34 mm
- Módulo de raíles de 1150 mm (sólo pesa 8 kg)

Opción

- Reposabrazos móviles integrados (lateral/central)
- Segundo respaldo : 580, 650 o 730 mm
- 3D colchón costado dormir

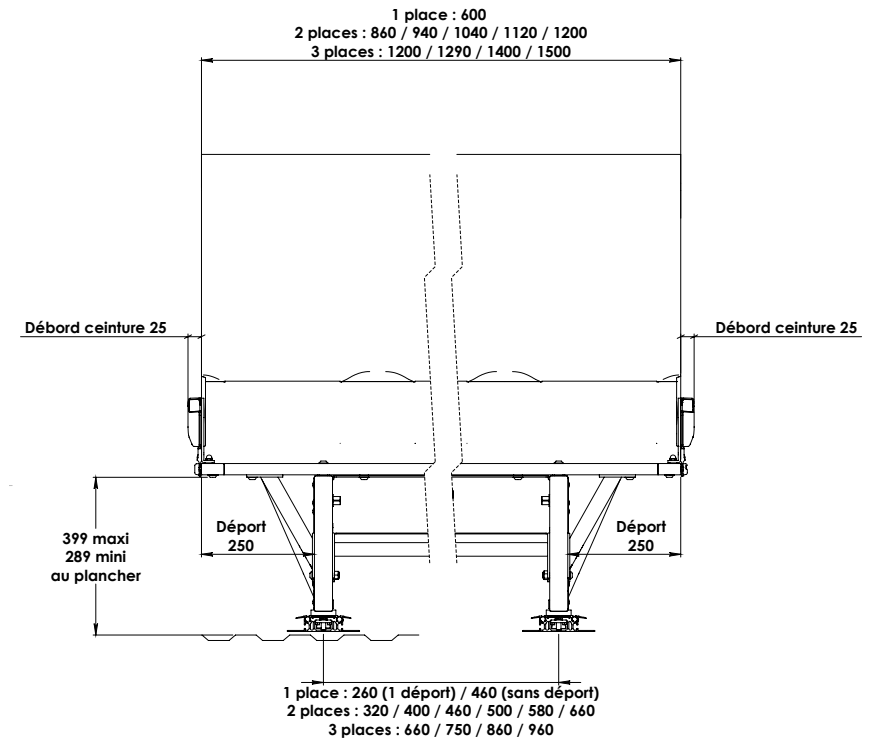
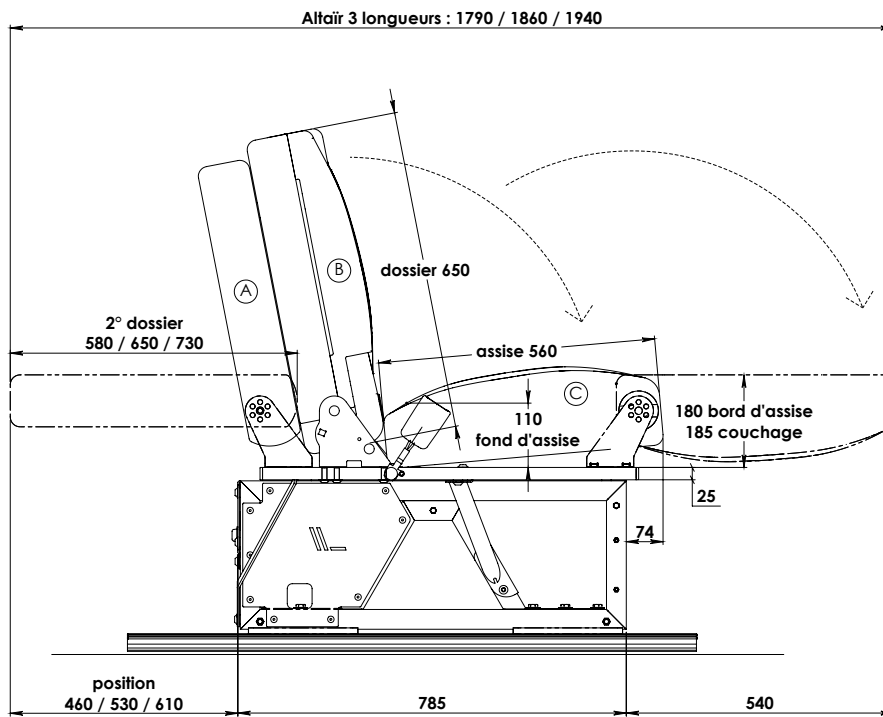

LÉGENDE

- A. Dossier arrière
- B. Dossier avec ceintures intégrées
- C. Assise

LEGENDE

- A. Hintere Lehne Herunterklappbar zur Bettverlängerung
- B. Rückenlehne mit integrierten Gurten
- C. Sitzfläche

LEGEND

- A. Rear Backrest
- B. Backrest with integral belts
- C. Sitting

LEYENDA

- A. Expediente posterior
- B. Expediente con cinturones integrados
- C. Base

Quality - Comfort - Safety

Created and manufactured with passion in France for over 40 years