

**AVANT**

GLISSIERES TRAFIC X82 phase 2

**Pilote** avec frein à main surbaissé

45,8

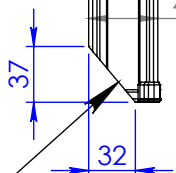

**ARRIERE**

tronçonnage angle glissière gauche côté vide poche

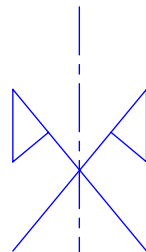
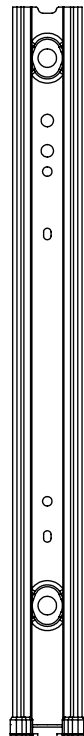

**AVANT**

GLISSIERES TRAFIC X82 phase 2

**Passager**

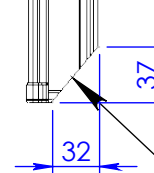
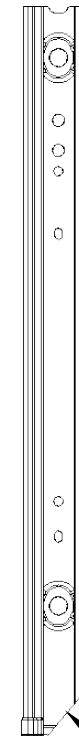

**ARRIERE**

tronçonnage angle glissière droite côté vide poche

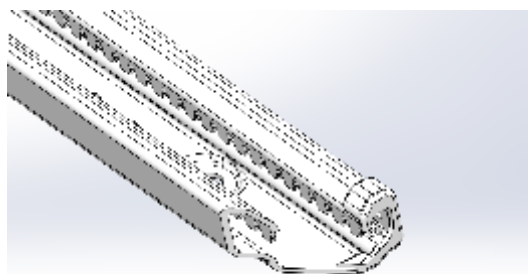

B	Ajout vue passager	18/03/2022	AL
A	Version d'origine	05/10/2022	AL
<b>Ind.</b>	<b>Evolution</b>	<b>Date</b>	<b>Par</b>
Tronçonnage AR glissiere Trafic X82 phase 2		<b>MATIERE:</b> S235	<b>POIDS:</b> 0.21Kg
SCOPEMA rue du Pouloueix - 87150 Oradour-sur-Vayres - France Tel : +33 (0) 555 78 11 49 ; Fax : +33 (0)555 78 15 88 ; Web : <a href="http://www.scopema.com">www.scopema.com</a>		<b>TRAITEMENT:</b> -	Mécanosoudage NF EN ISO 3834-2
Client: -		Tolérances générales Norme ISO 22081	Ech: 1:5
Ref: -		<b>SCOPEMA</b> RIB SEATING SINCE 1961	<b>A4</b>
Ce plan est la propriété de SCOPEMA Il ne peut être communiqué à des tiers ou reproduit sans autorisation écrite de SCOPEMA. This drawing cannot be printed or issued to anybody without SCOPEMA Authorisation			

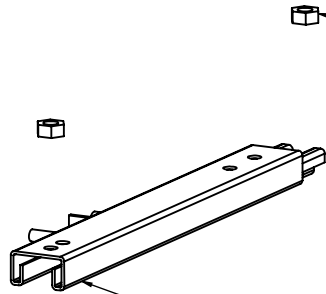
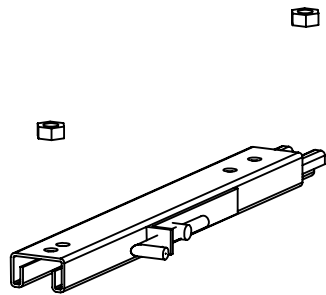

( fWfci gA %\$

[ `]gg], fYgXfc f]] ]bY `HF5: 7 `L, &

( j ]gH <7 `A %\$! % `YbXi ]hY `ZY ]b `ZYh &) B"a

**HFCB7 CBB9F `Yg&d]cbg**  
**gci g`U[ `]gg], fY [ Ui VXY**

VUgY `hci fbUbhY `7 6HC &\$8 &

**D@9F `U`dUHY `a fWU`]ei Y**  
**j Yfg`f]bhf]Yi f`Xi `WU]ggcb**

( j ]gH <7 `A %\$! &) !" \$B"a

WU]ggcb `Xfc f]] ]bY `HF5: 7 `L, &

]bX `8 : fWfci `bmgcd `A %\$!!2 fWfci `A %\$  
 ..... j ]gH <7 `A %\$! % !!2 YbXi ]hY `ZY ]b `ZYh  
 ]bX `7 : dfWgcb `d ]U[ Y `dUHY `Uj UbhWU]ggcb  
 Z `Wci d`Y XY gYffU[ Y  
 ]bX `6 : j ]gH <7 `A %\$! &\$!!2 `H <7 `A %\$! %

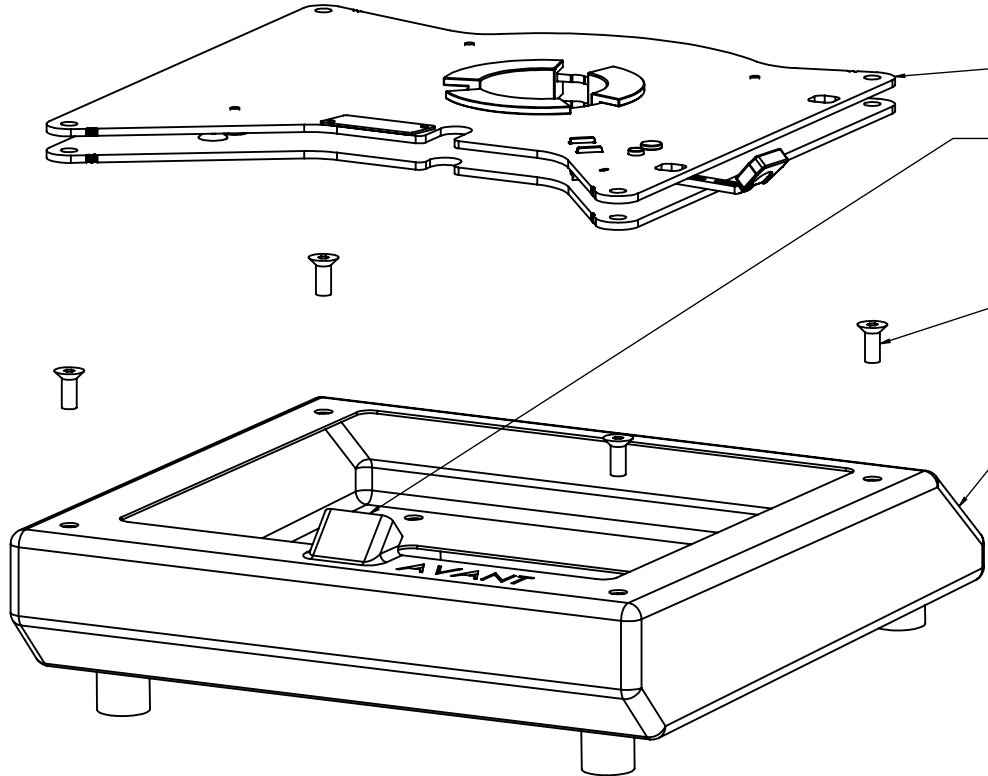

{ [ ] œ ^ Å æ ^ Å ~ ! } œ ø  
 l, l ~ ! Å a \* ^ Å ç i ä å ^ Å œ • œ ^ !  
 U Ö P C E V S V A U Ö Z Ö Ä I G

		<b>ÔÓVUGEÖG</b>	Ö <b>€</b> <b>FF</b> <b>EE</b> <b>J</b> <b>CS</b> Ô <b>CF</b> <b>EU</b> <b>EE</b> <b>I</b> <b>CS</b> Ó <b>G</b> <b>FF</b> <b>EE</b> <b>F</b> <b>CS</b> CE <b>HF</b> <b>EE</b> <b>EE</b> <b>F</b> <b>CS</b> Ø Ö <b>Ö</b> <b>CS</b> <b>Ö</b> <b>Ø</b> <b>Q</b> <b>Q</b>
Ô&@  ^ÅÉÉ	T æã+^ÅK		
Viææ{ ^ } óK	Ô]a} óK		