

ACA60AD  
+ CBTRO02D2

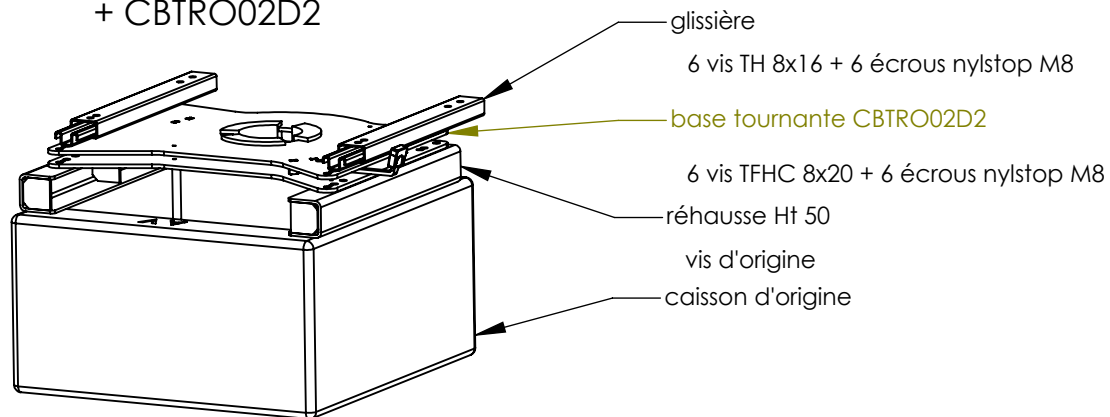

ACA60AG  
+ CBTRO02G2

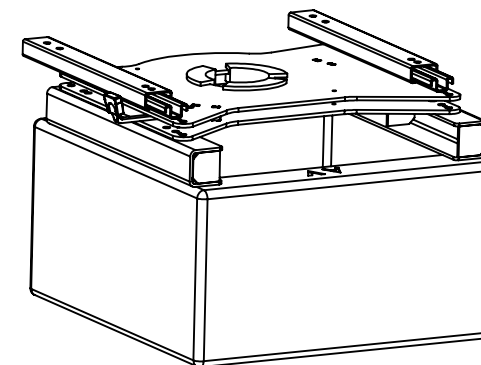

ACA59A

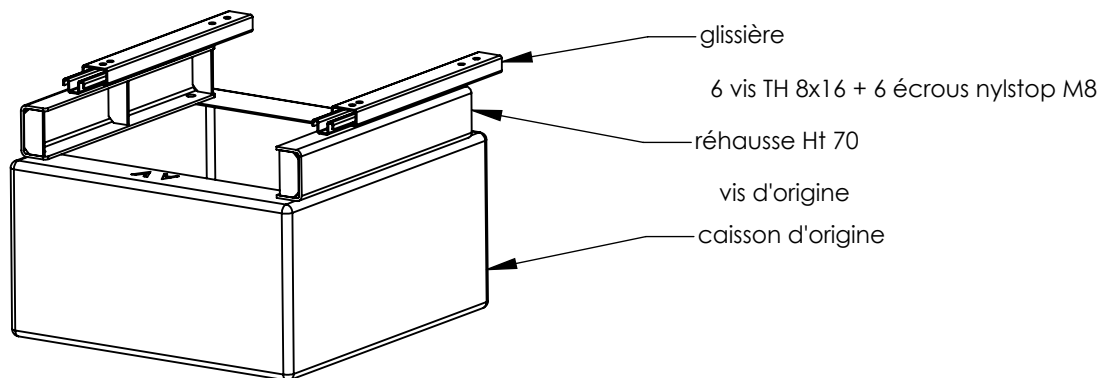

ind B, nov 2007 : modif BT modèle trou central

